



MYS850LF

HANDLING | ASSEMBLY | DISPENSING

KEY BENEFITS

Uses the same controller as larger Yaskawa robots

Easy vision integration with MotoSight 2D, a Cognex In-Sight based vision system

Yields extraordinary production results, while requiring minimal capital investment

High work envelope to mounting surface ratio

Flexible asset; easily re-deployable as production needs change

SPECIFICATIONS

10 kg maximum payload

850 mm radial reach

420 mm U-axis stroke

CONTROLLERS



DXM100



FS100



MLX200

- 4-axis SCARA robot ideal for high-speed handling and assembly systems.
- Offers superior performance in applications such as assembly, dispensing, part kitting, small part handling, case packing, lab automation, packaging, solar and semiconductor processing.
- Ideal for multi-process systems requiring pick-and-place capability.
- Easily integrates with existing robot applications to expand current automated processes.
- Rounds out the Yaskawa product line of 4-15 axis robots with payloads of 1-800 kg.
- Uses same controller as other Yaskawa robots. Enclosure size may vary depending on robot size and payload.
- Offers high speed in a compact form that requires minimal mounting space.
- Features a radial reach of 850 mm, long (420 mm) U-axis stroke and 10 kg maximum payload.
- External axes available, further expanding the capabilities of this flexible asset.
- High repeatability with compliance in all axes make these robots ideal for assembly tasks.
- Wide variety of fieldbus connectivity available.

MYS850LF

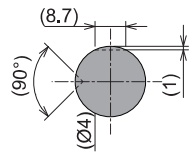
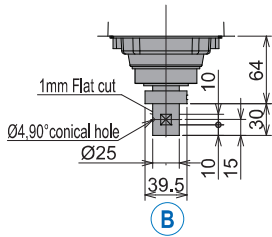
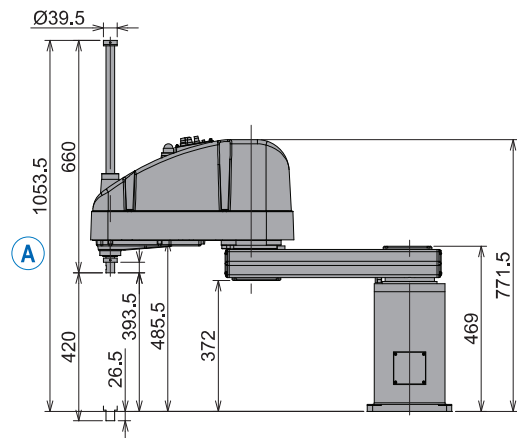
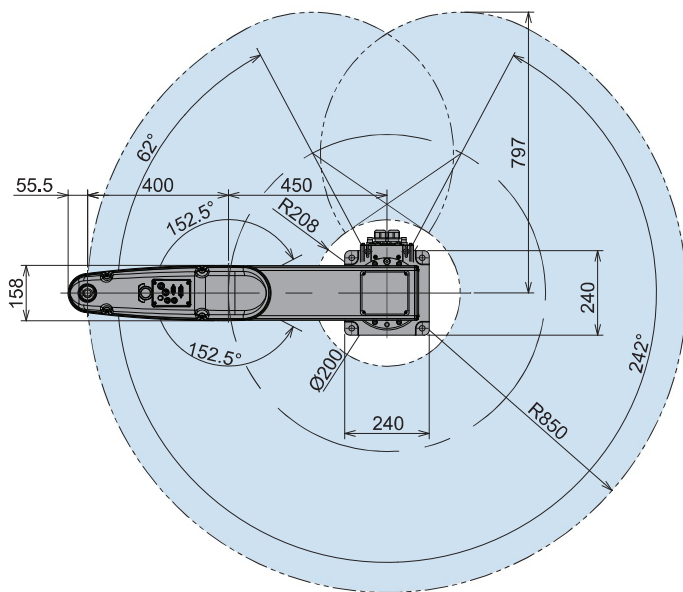

VIEW A

VIEW B

All dimensions are metric (mm) and for reference only.
Request detailed drawings for all design/engineering requirements.

SPECIFICATIONS

Axes	Maximum motion range [°]	Maximum speed [°/sec.]	Allowable moment of inertia [kg•m ²]	Repeatability [mm]	Controlled axes	
S + L	850 mm	-	-	±0.025	4	4
S	+242/-62	424	-	-	Payload [kg]	5 Rated/10 Max
L	±152.5	678	-	-	Radial reach [mm]	850
U	420 mm	2,350 mm/s	-	±0.01	U-axis stroke [mm]	420
R	±360	2,415	0.02 Rated/0.25 Max	±0.005°	Weight [kg]	48
					Power rating [kVA]	1.25

NOTE: Maximum speed and moment of inertia may vary depending on load.

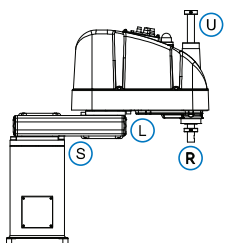

AXES LEGEND

- S-Axis: 1st Horizontal Arm
- L-Axis: 2nd Horizontal Arm
- U-Axis: Upper/Lower
- R-Axis: Rotate

Representative SCARA model



工博士网: www.gongboshi.com
 官 网: www.gongboshi.org
 邮 箱: service@gongboshi.com
 电 话: 021-31666777