

FANUC机器人 M-710iC/50S

手腕允许负载曲线图

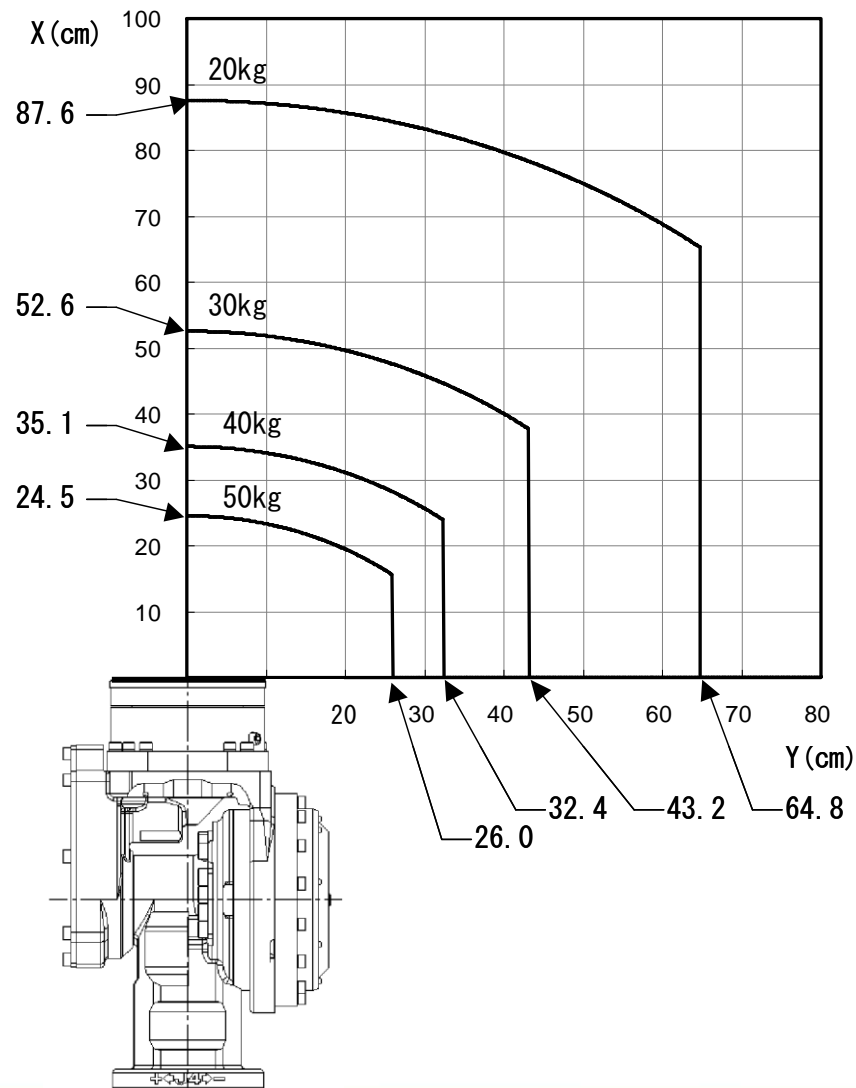

末端执行器安装面尺寸

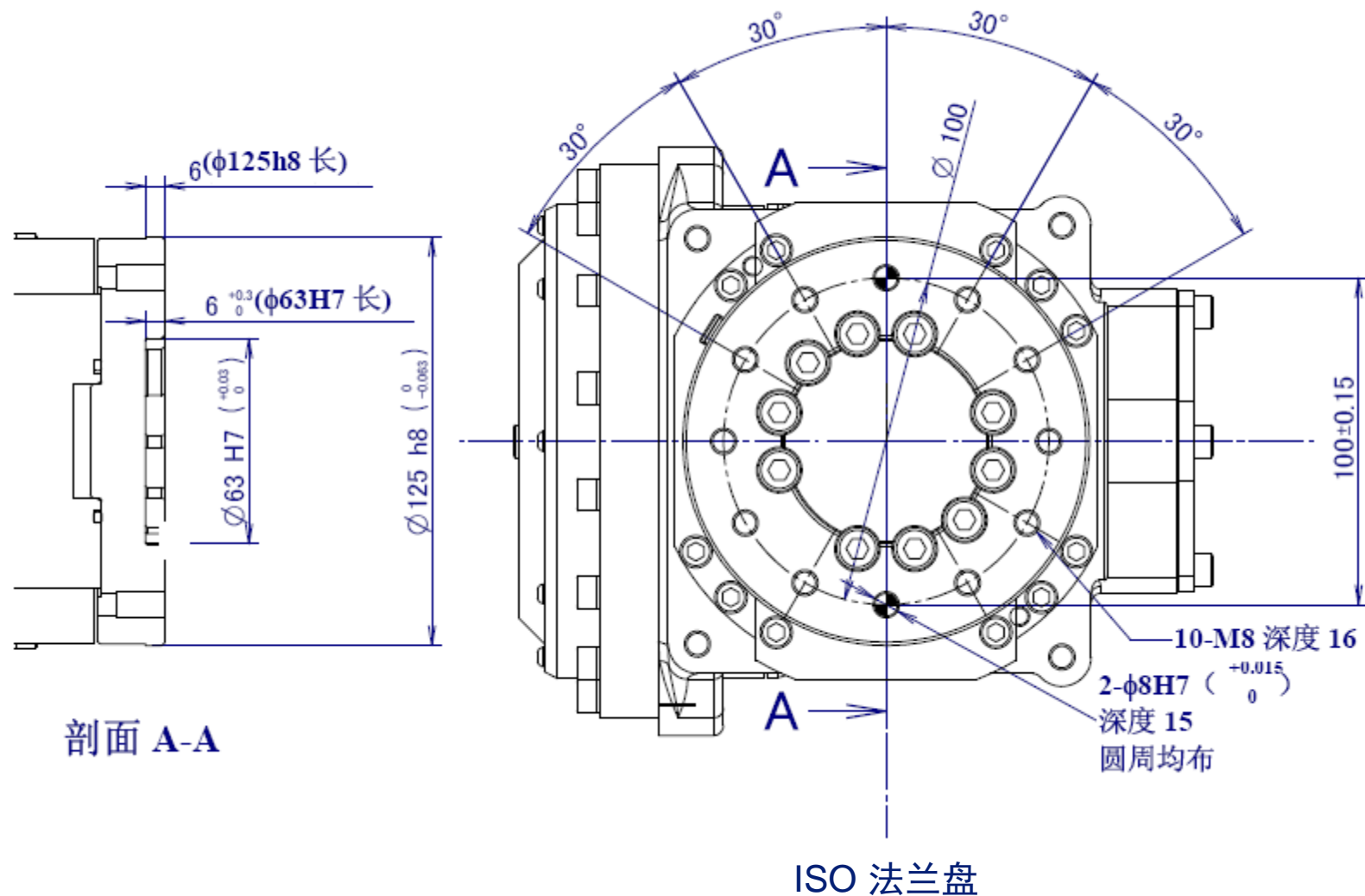

末端执行器安装面尺寸

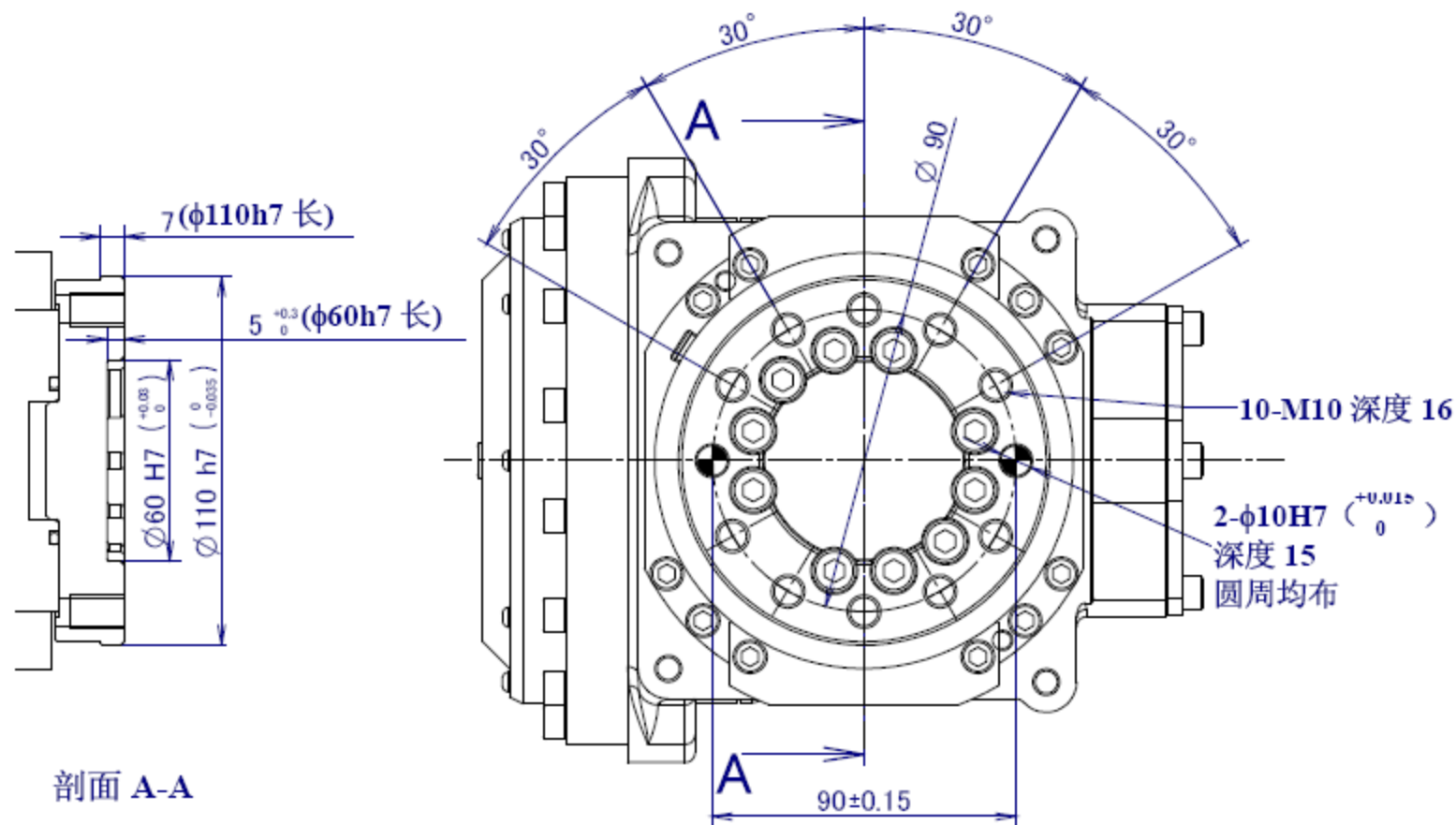

FANUC 法兰盘

末端执行器安装面尺寸

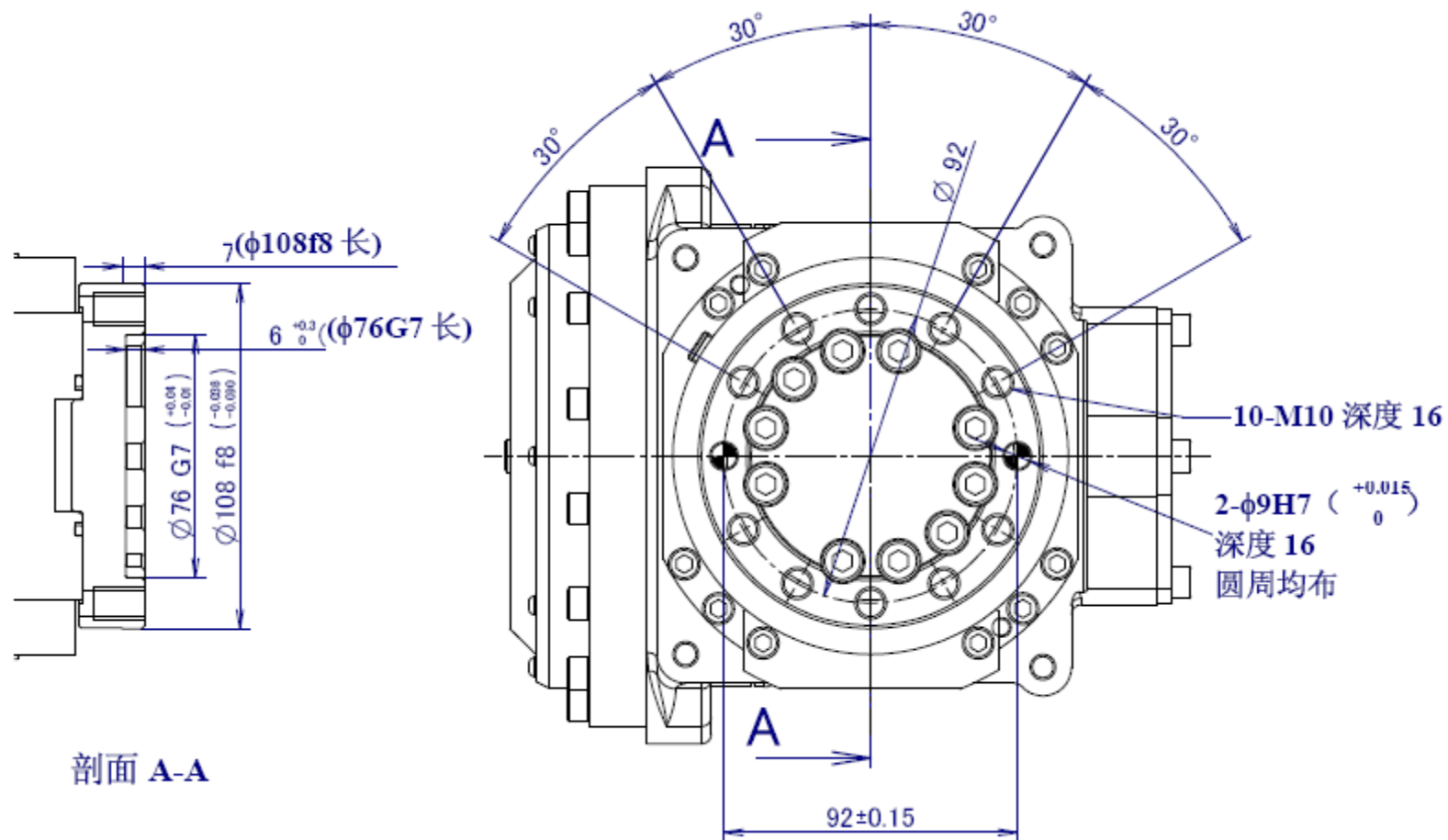

安装尺寸（底座）

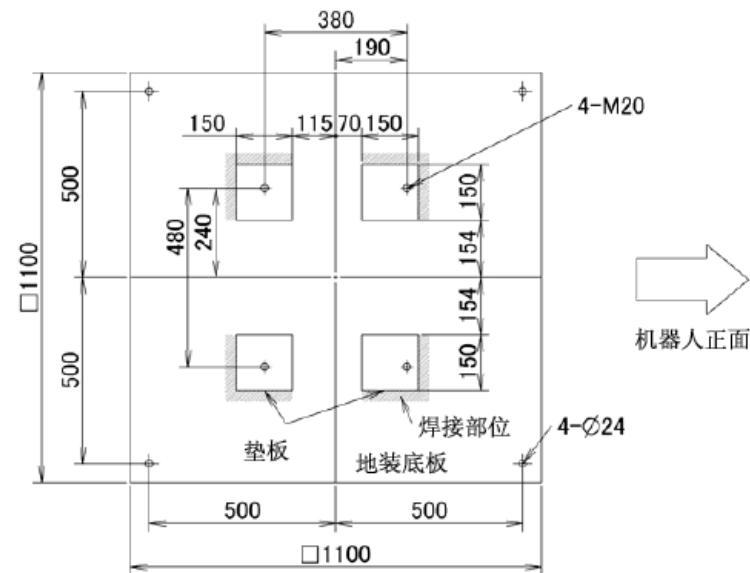
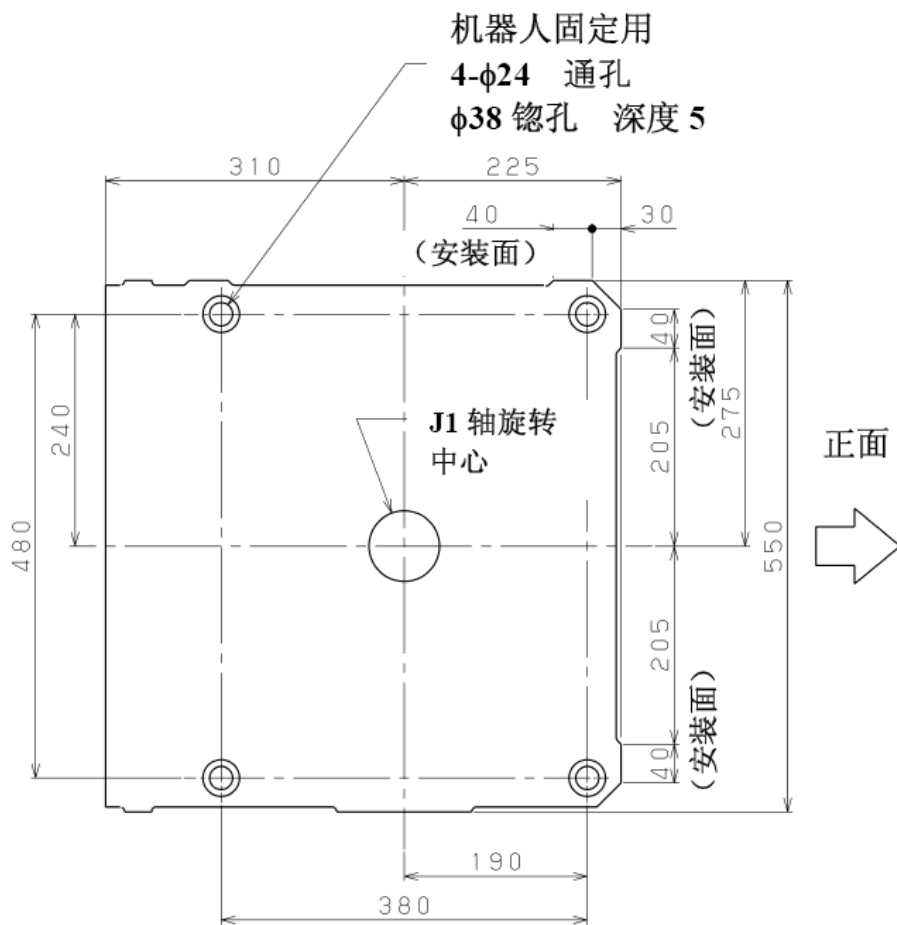

机器人固定螺栓
M20×50 (4个)
性能等级 12.9
拧紧力矩 529.2Nm (54kgfm)

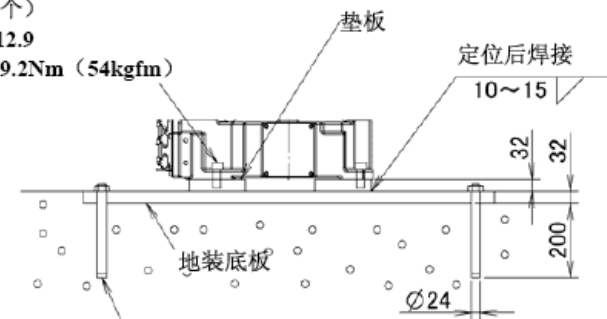

设备安装面尺寸

