

FANUC机器人 R-2000*i*C/165F

手腕允许负载曲线图

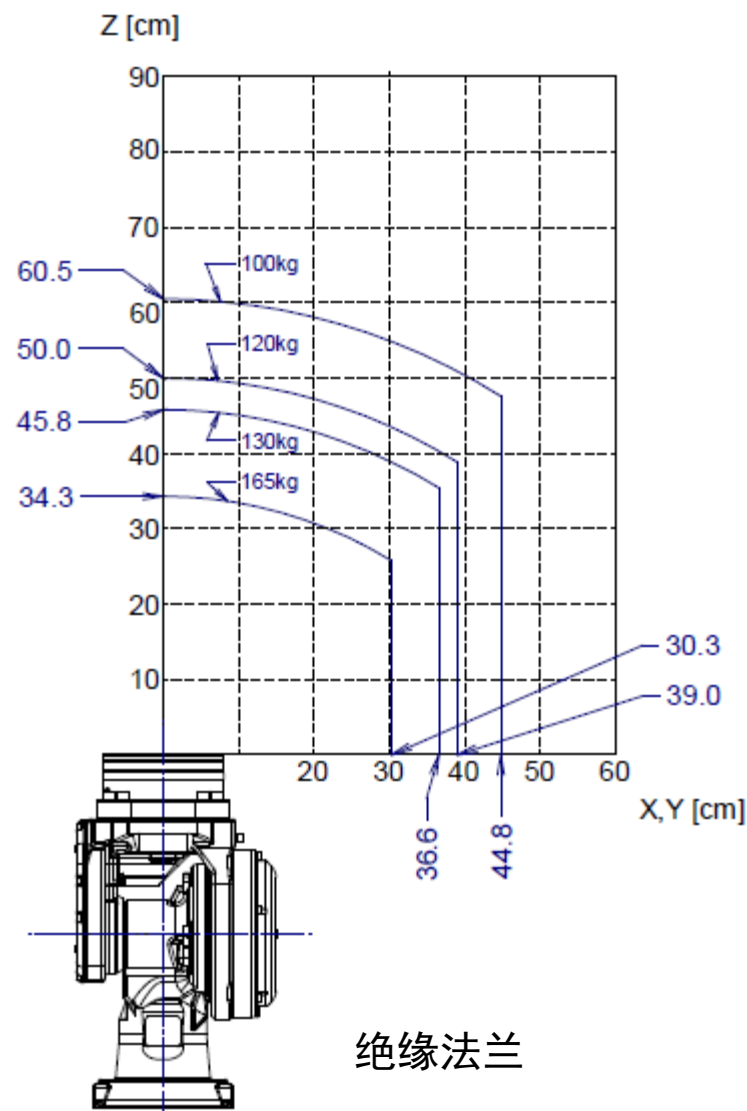

设备安装面尺寸

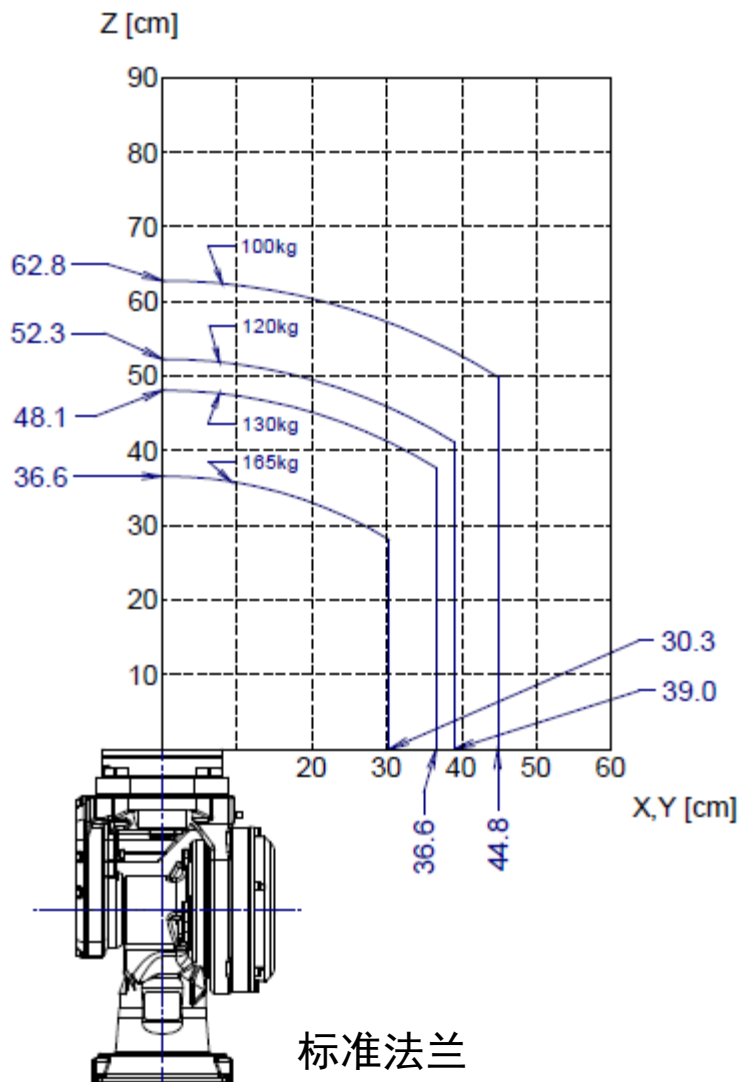
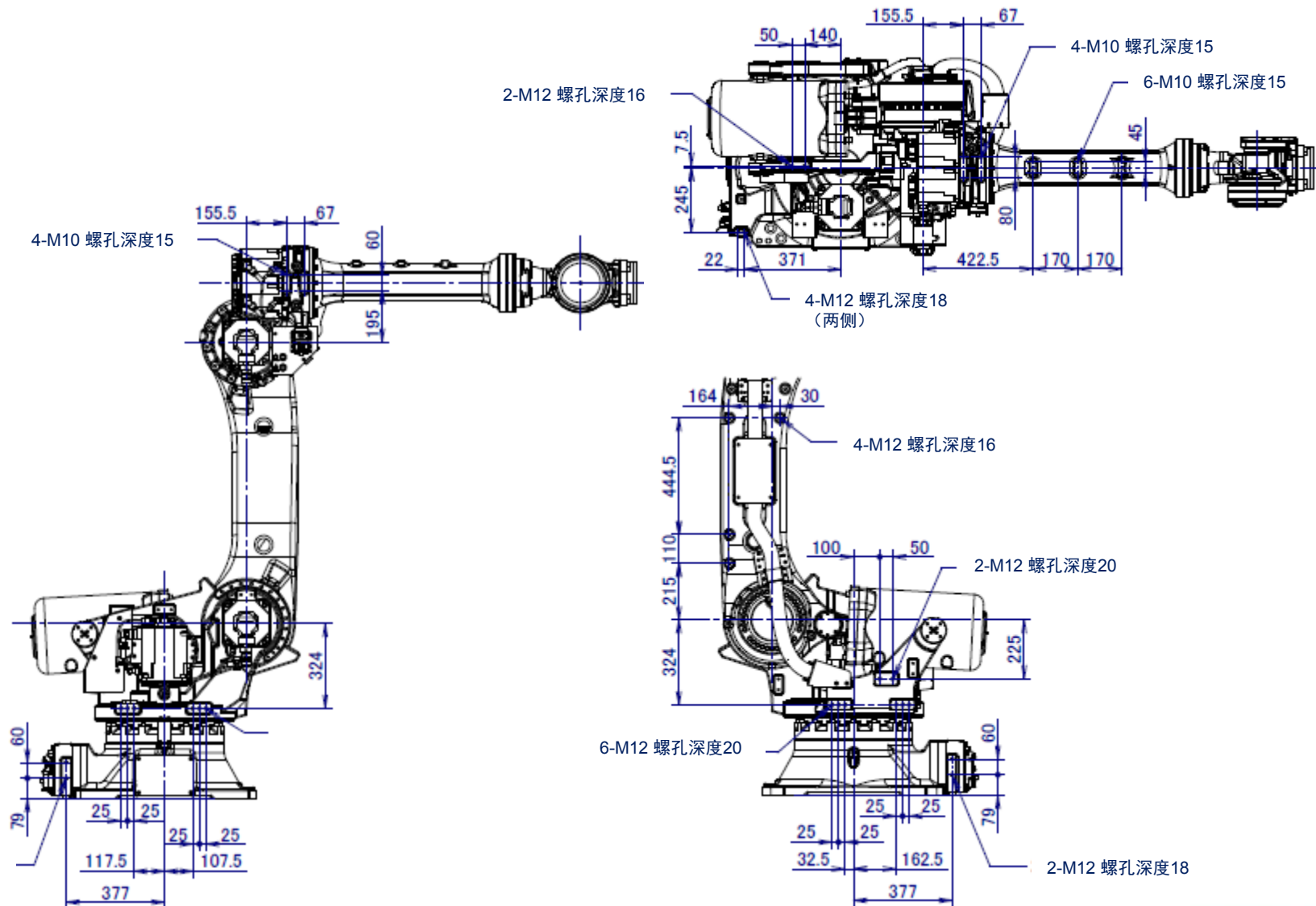

末端执行器安装面尺寸

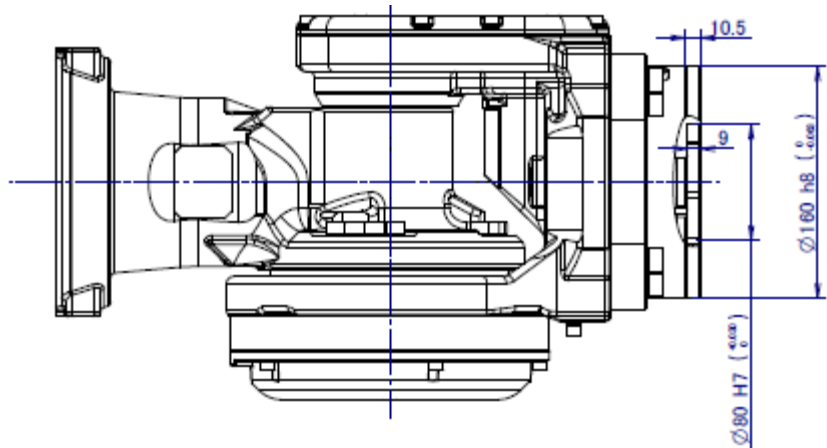

标准法兰

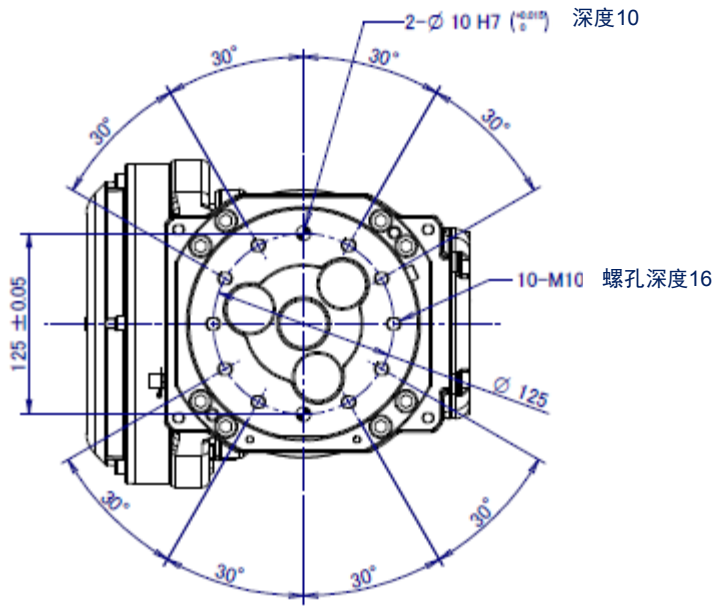
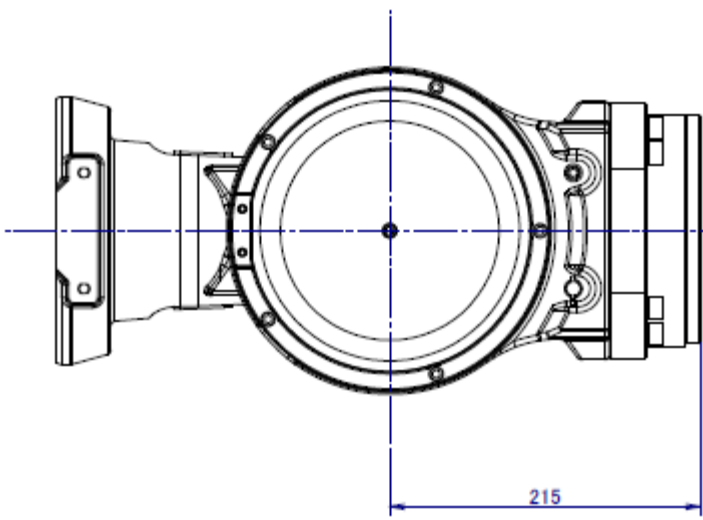

末端执行器安装面尺寸

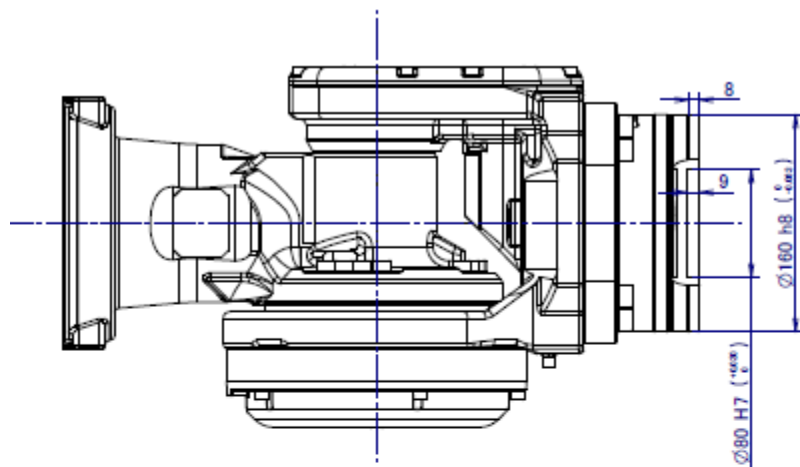

绝缘法兰

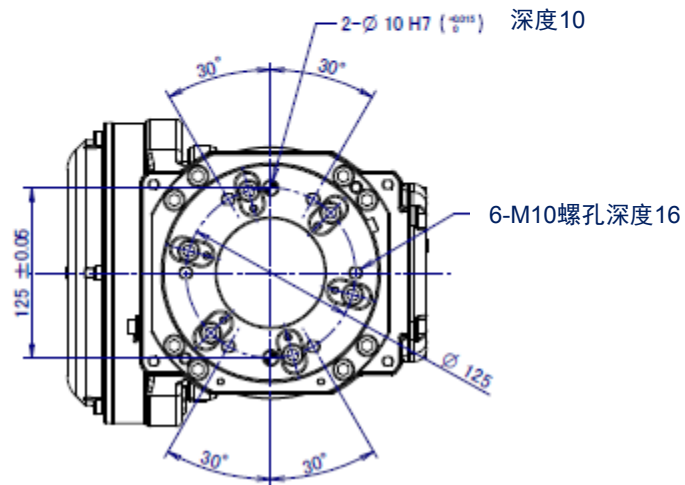
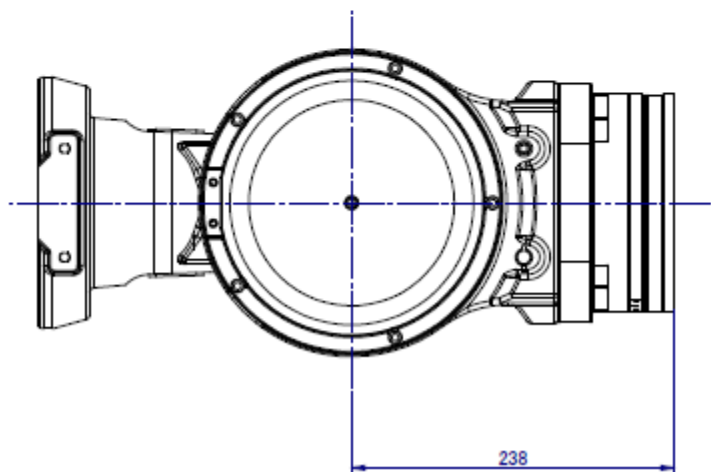

安装尺寸 (底座)

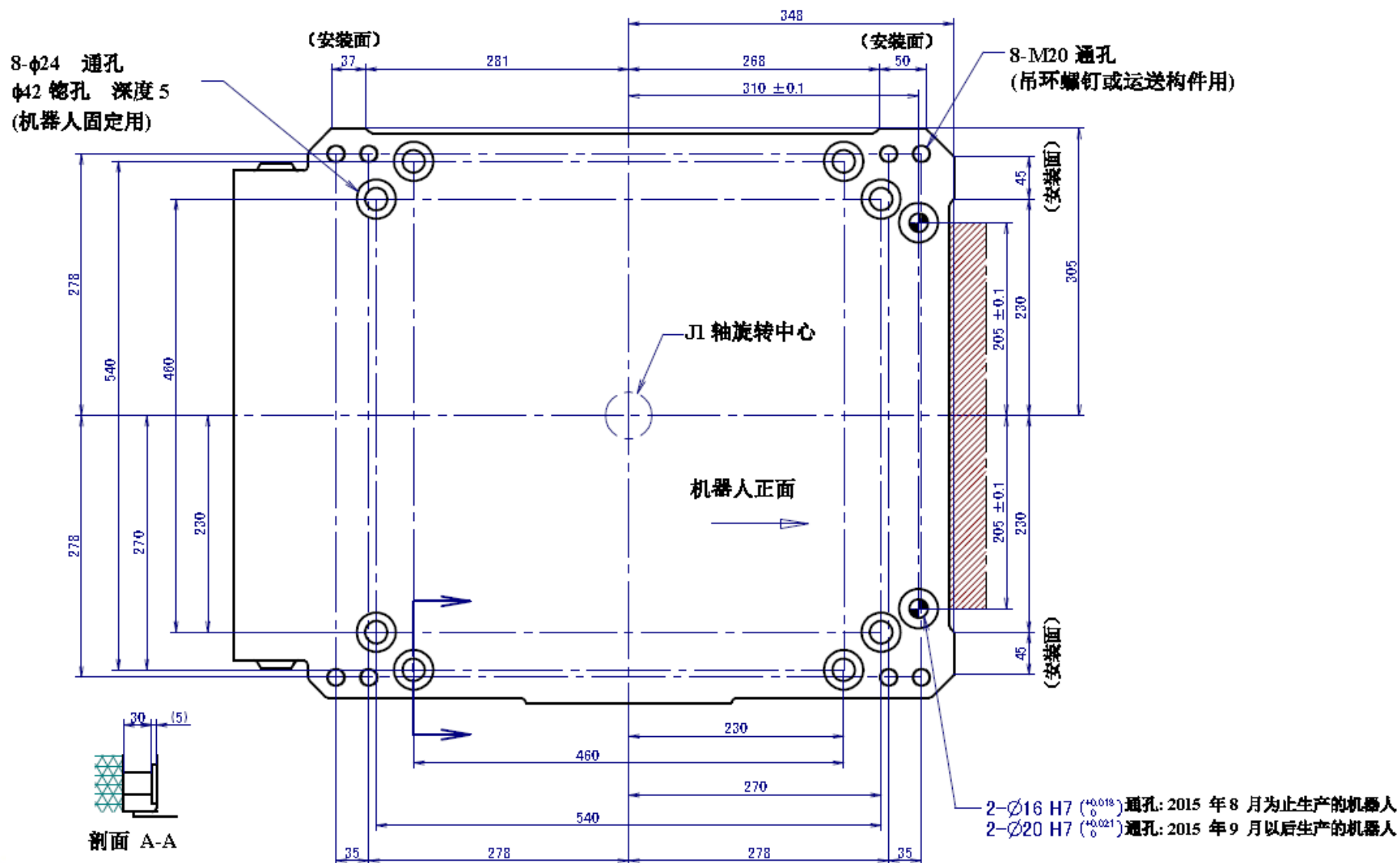

使用标准垫板安装方法

