

FANUC机器人 M-410iB/450

手腕允许负载曲线图

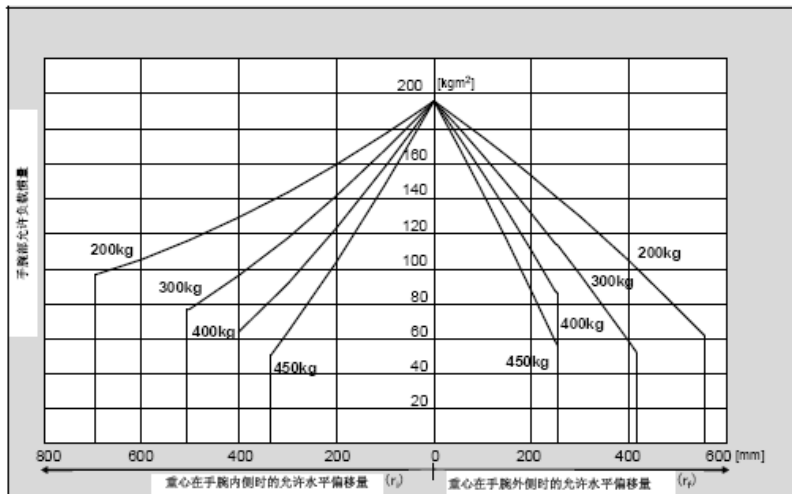

手腕部允许负载线图(水平偏移/标准惯量)

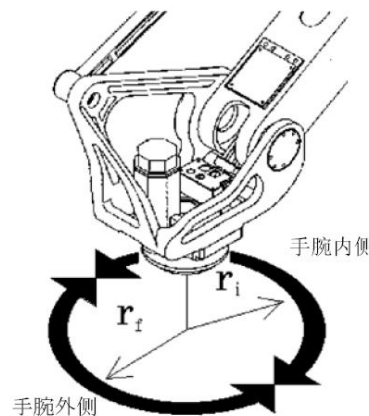

手腕部负载条件

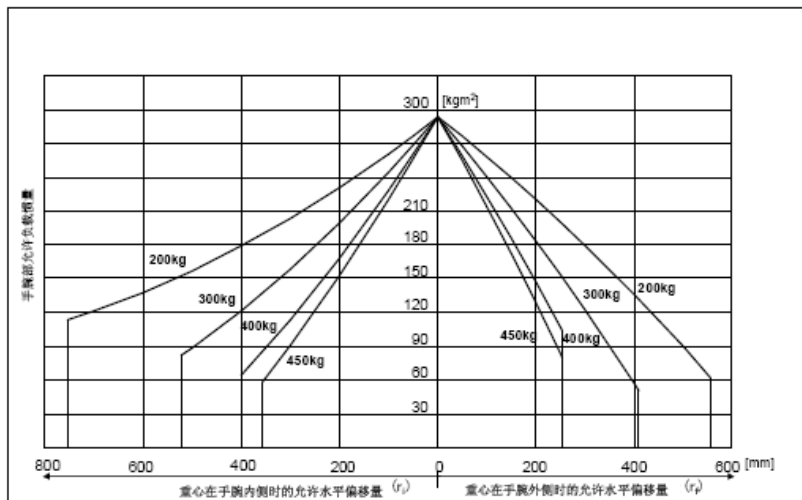
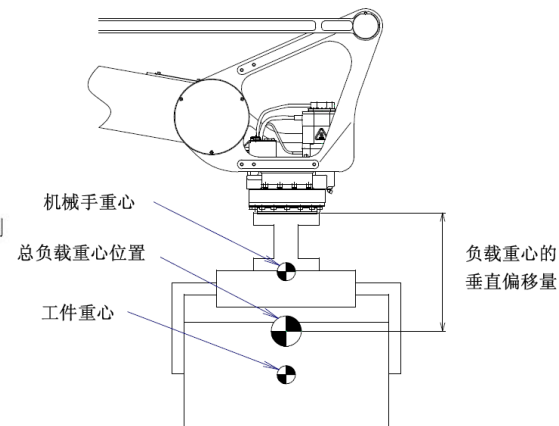

手腕部允许负载线图(水平偏移/高惯量)

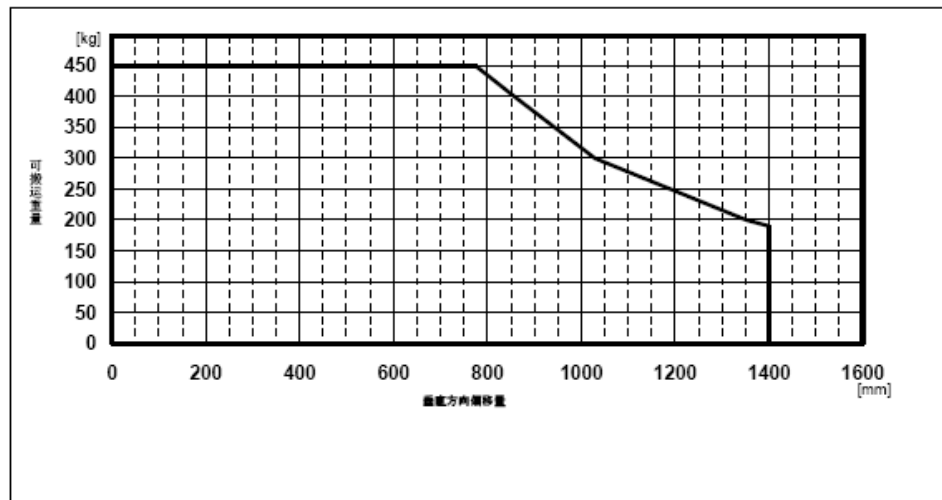

手腕部允许负载线图 (垂直偏移)

*本资料仅供参考，最终解释权归上海发那科所有

末端执行器安装面尺寸

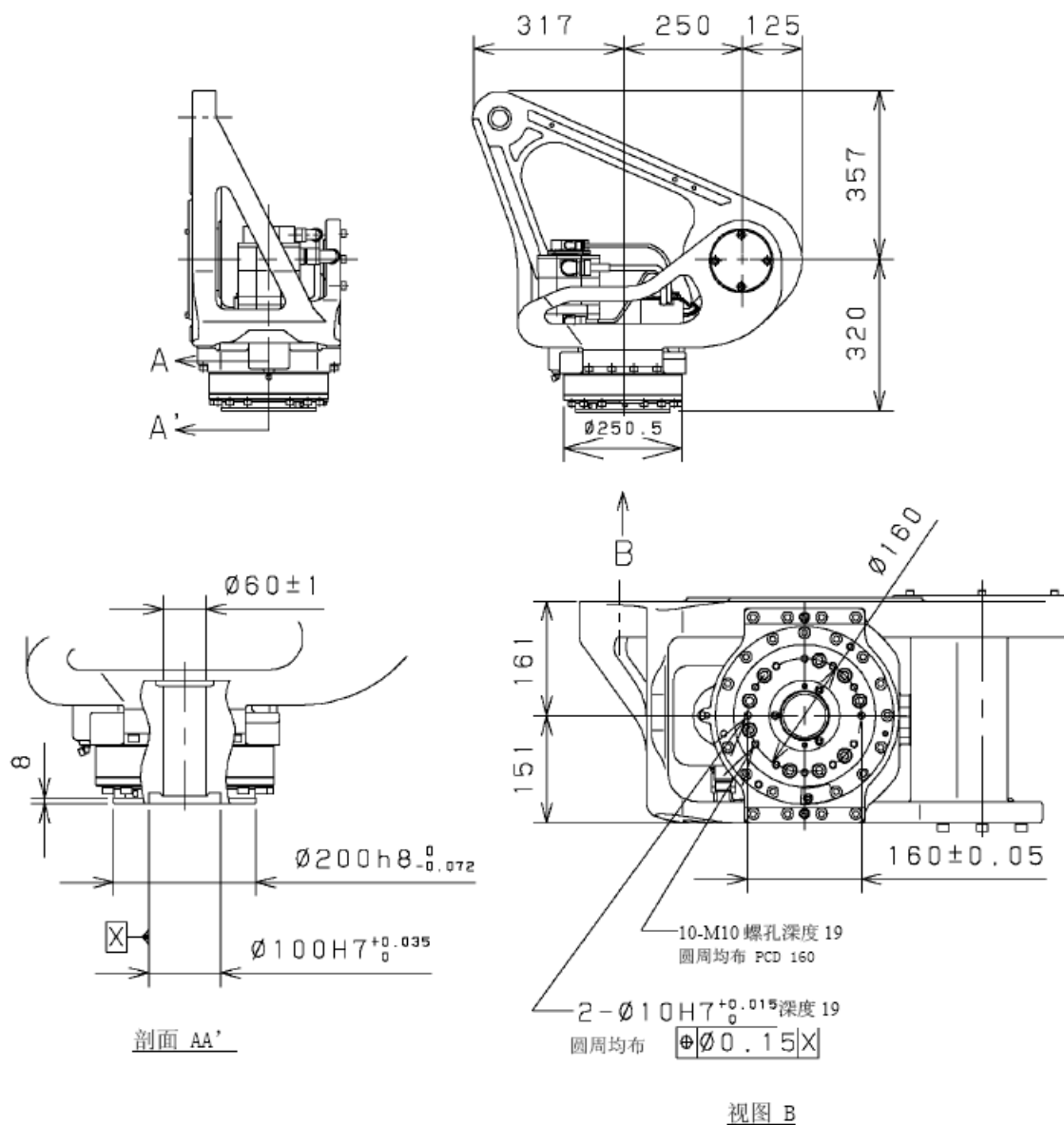

安装尺寸（底座）

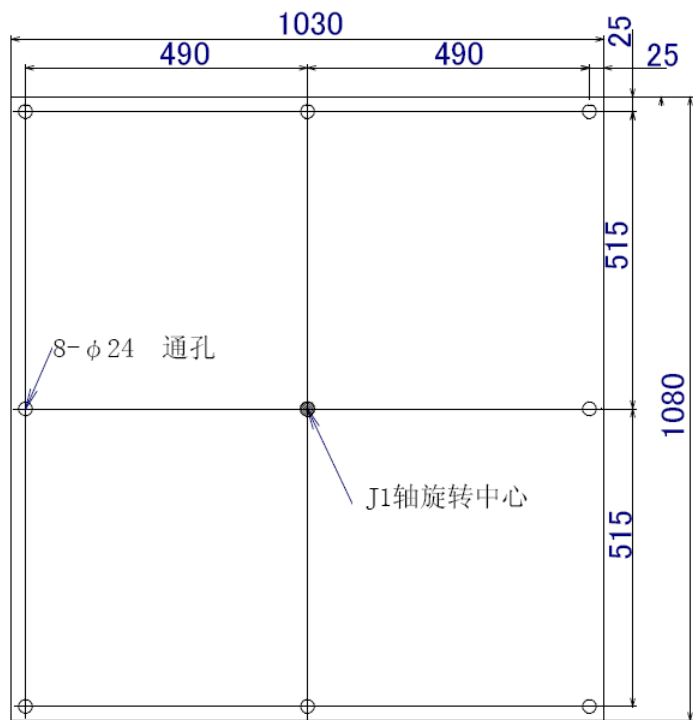

注释) 用图示的 8 处通孔来固定机器人。

➔
机器人正面

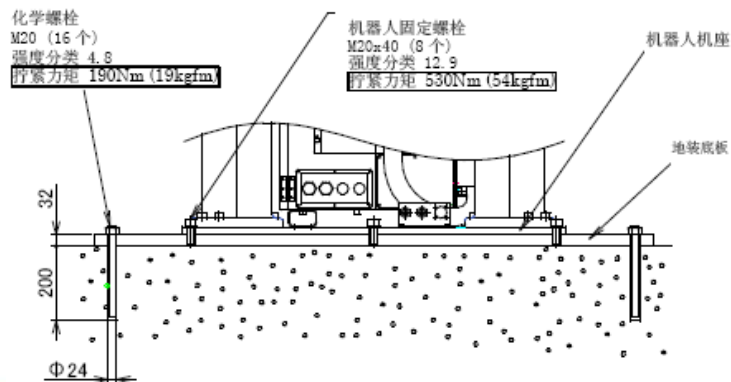
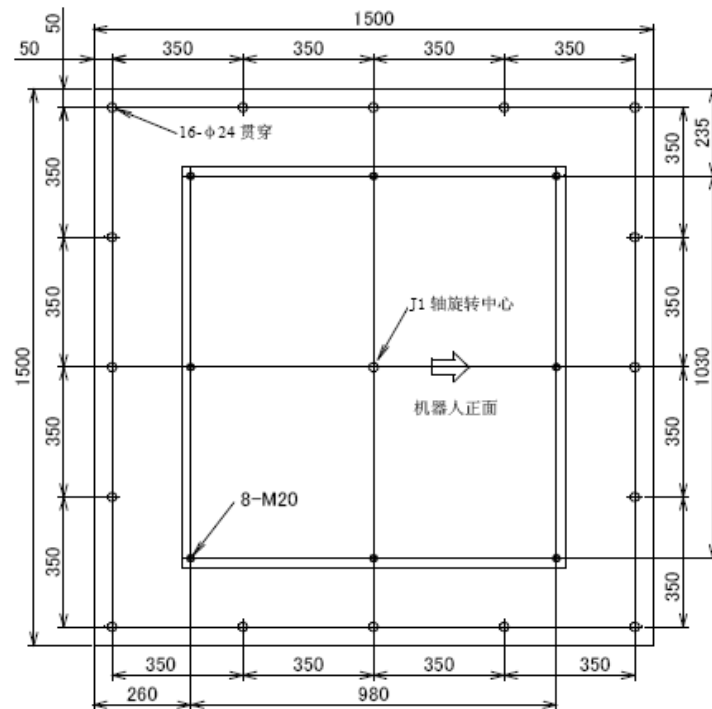

设备安装面尺寸

