

FANUC机器人 M-2iA/3S

手腕允许负载曲线图

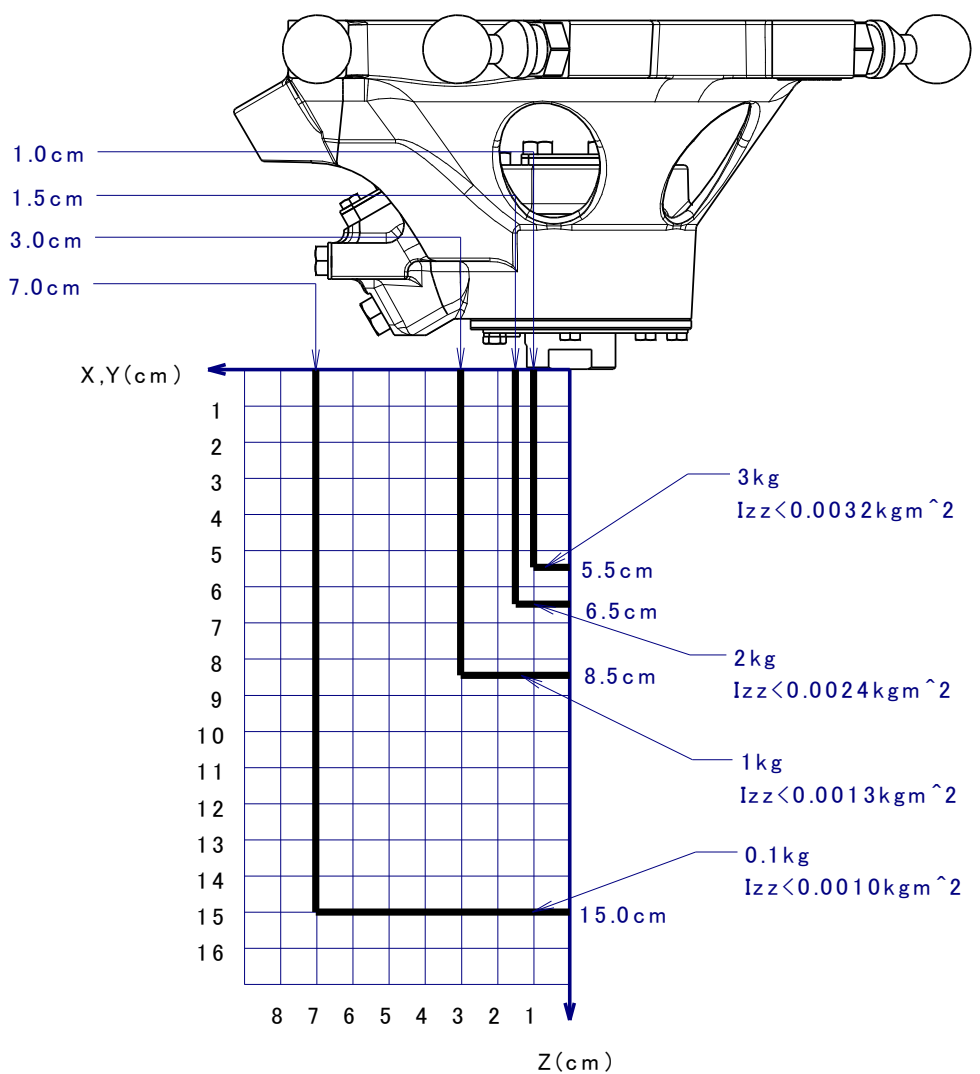

末端执行器安装面尺寸

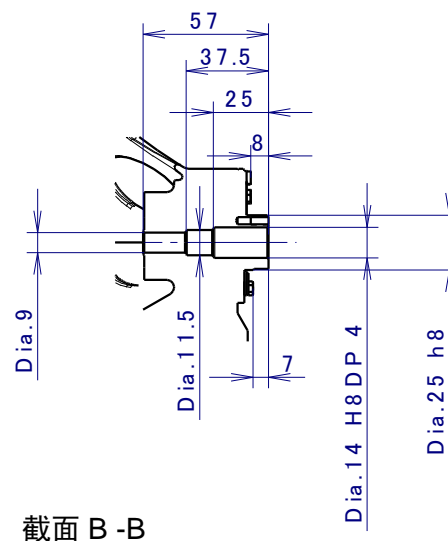
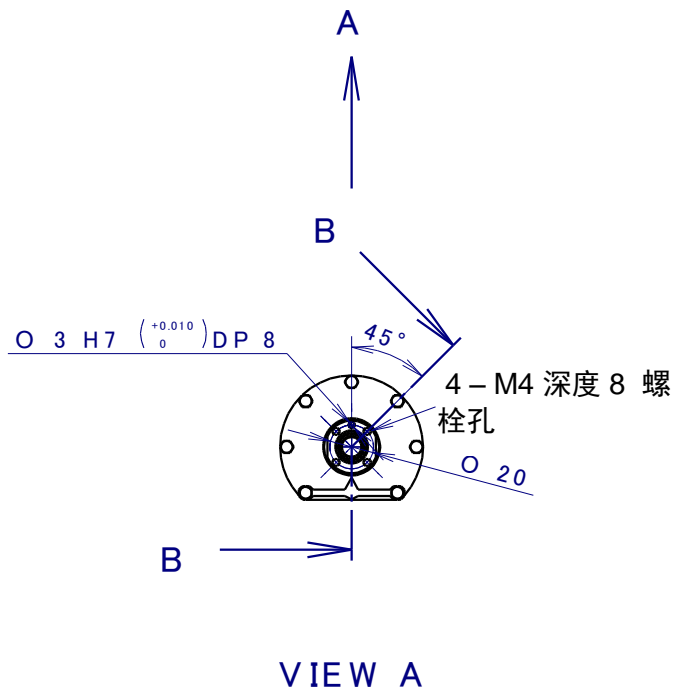
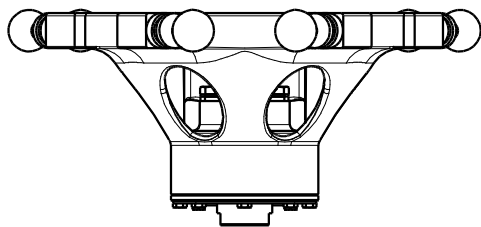

最大负载容量：3 kg

安装尺寸 (底座) (1/2)

机座安装面

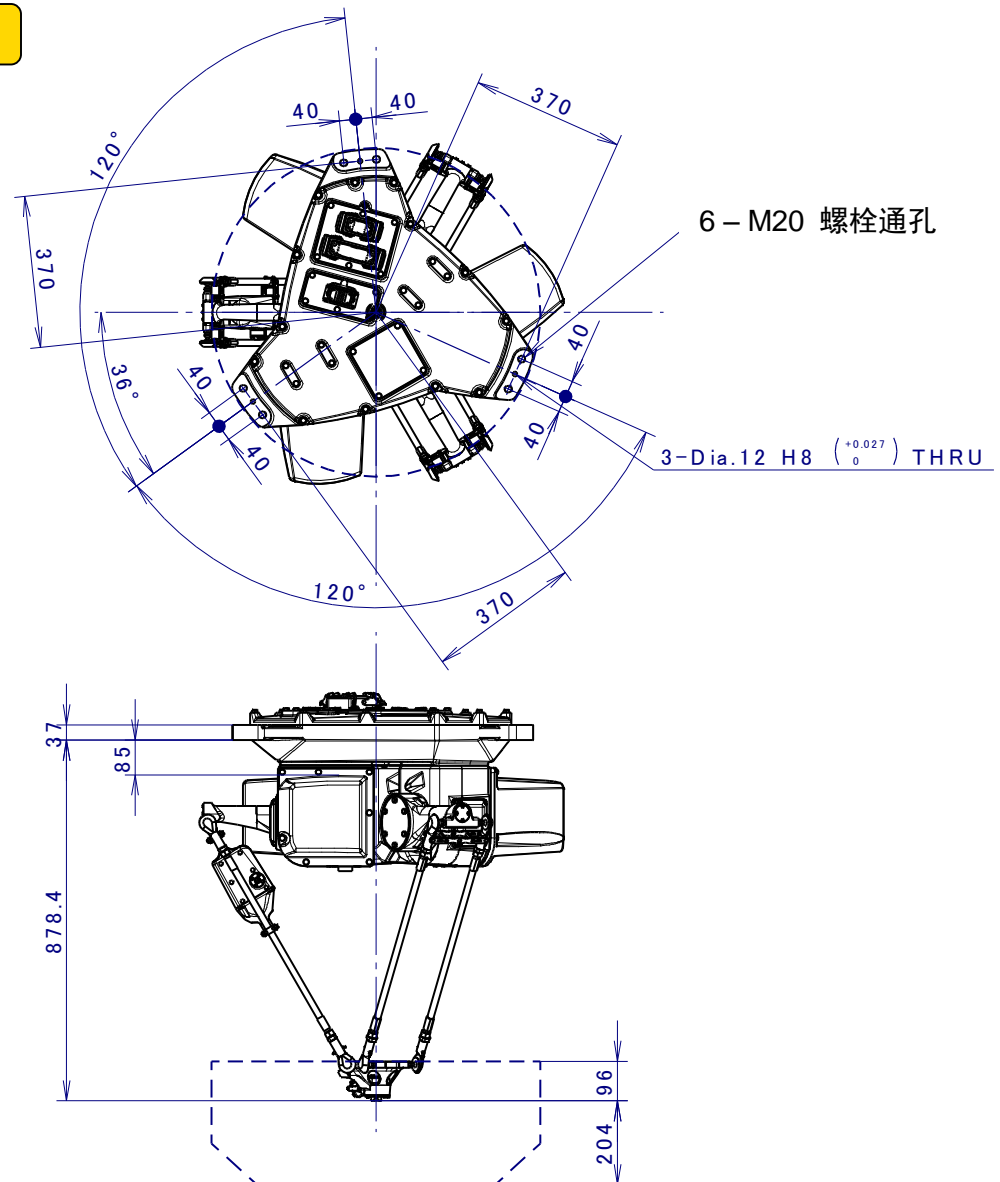

安装尺寸 (底座) (2/2)

连杆干涉区域

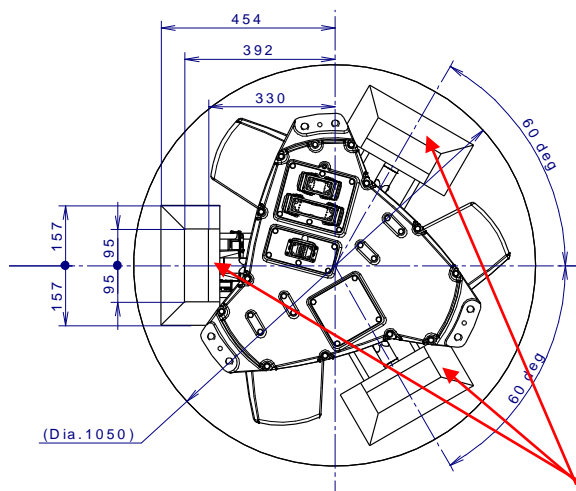
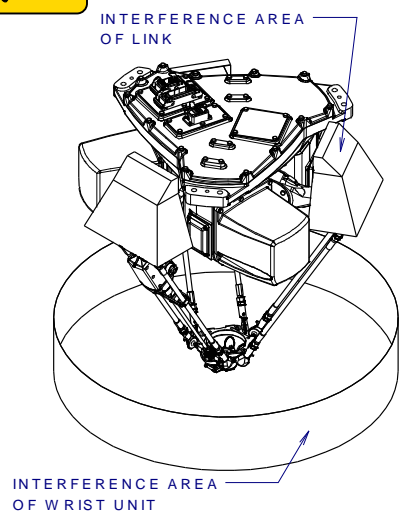

连杆运动区域，请确认不会与基架结构干涉

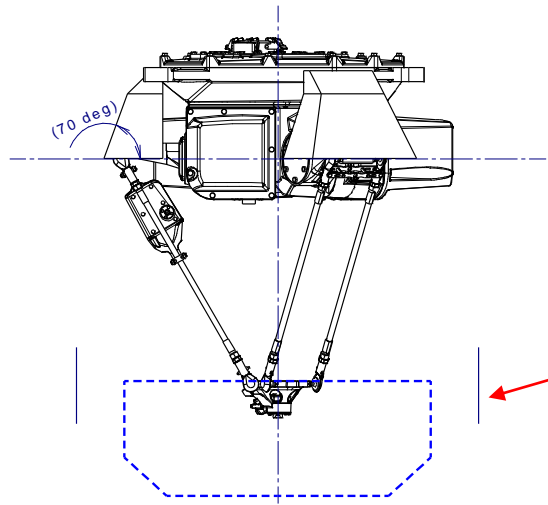
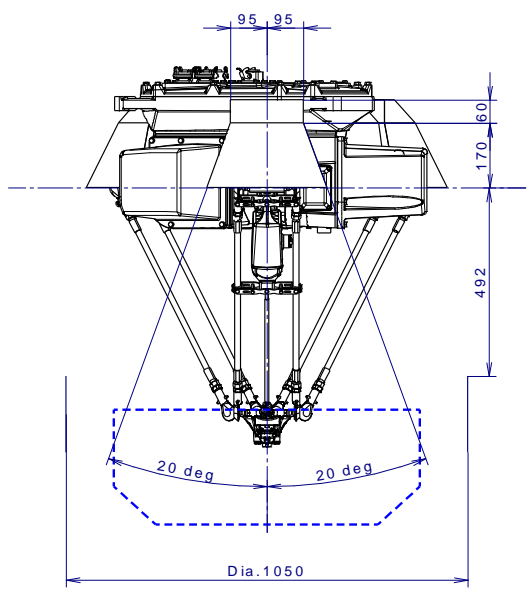

手腕部干涉区域

设备安装面尺寸

8 - M8 深度 18 螺栓孔

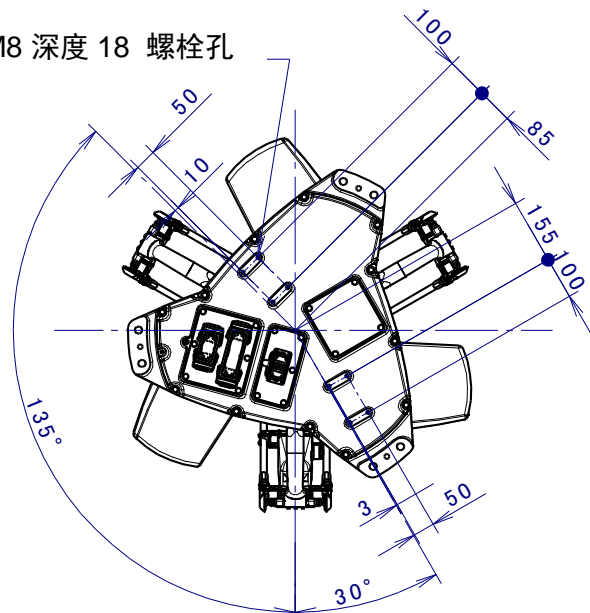

2 - M5 深度 11 螺栓孔

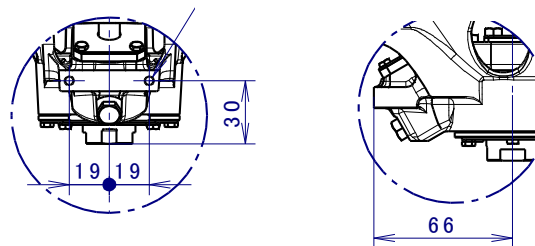

A 向详细

B 向详细

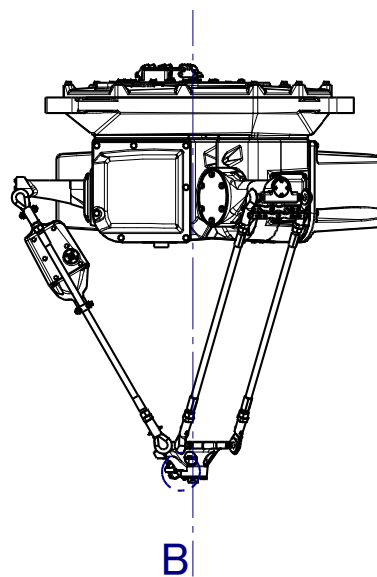
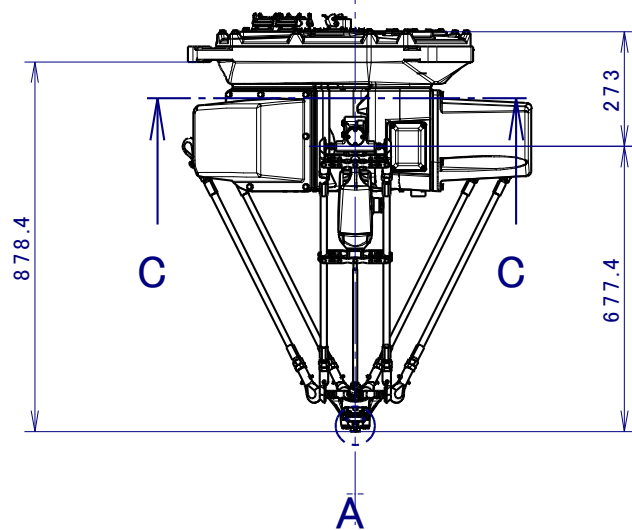

4 - M6 深度 12 螺栓孔

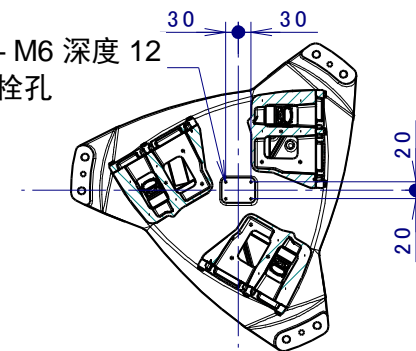

截面 C - C