

FANUC机器人 M-2000iA/1200

手腕允许负载曲线图

M-2000iA/1200 (标准)

M-2000iA/1200 (1350kg 选项)

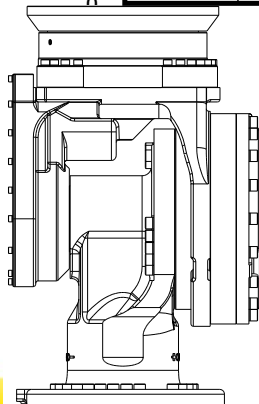
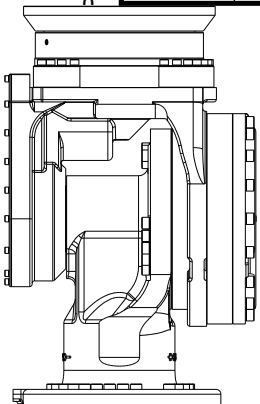
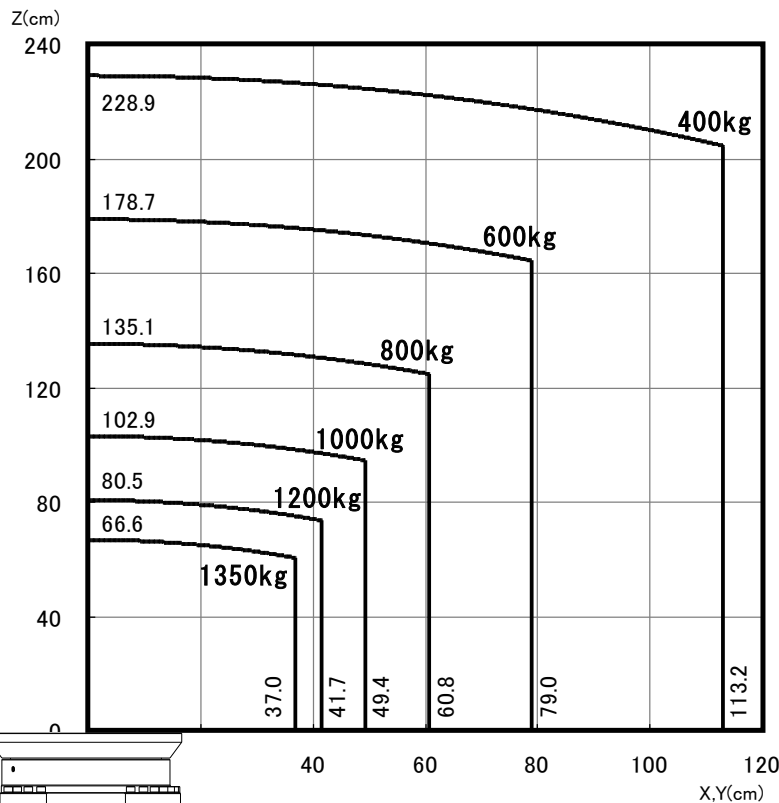
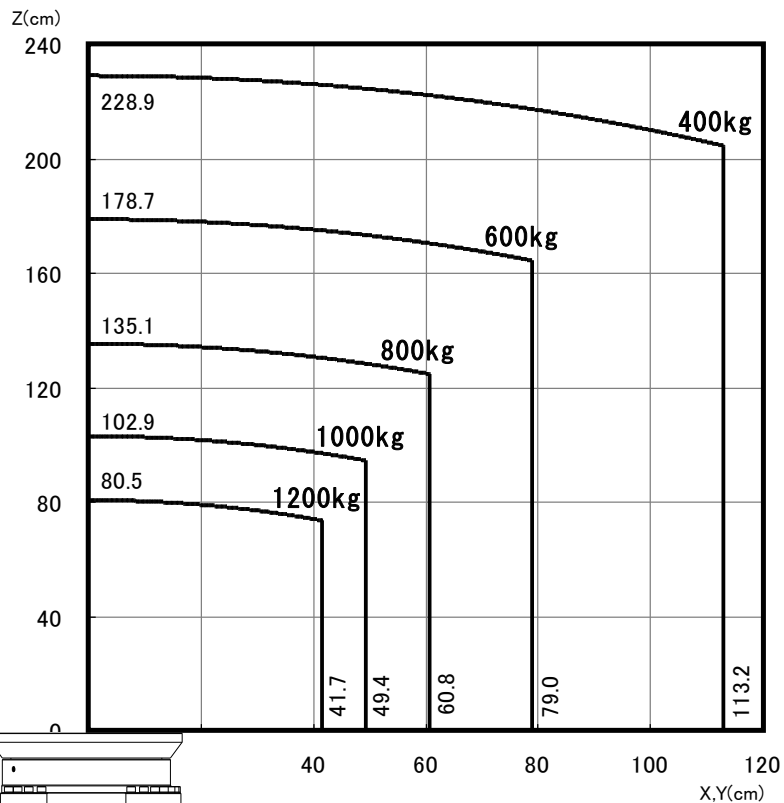

末端执行器安装面尺寸

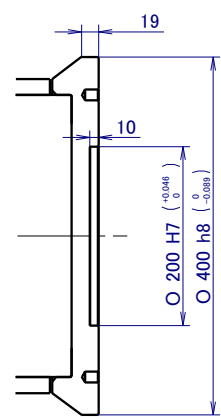
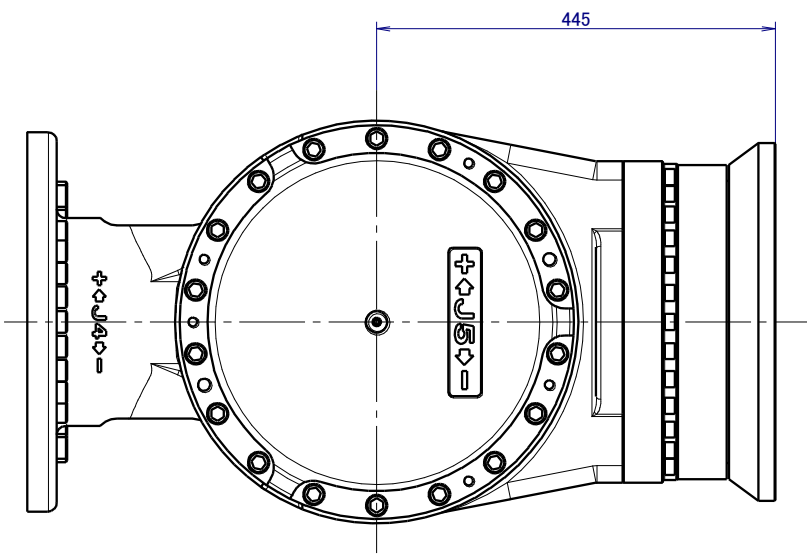

SECTION A-A

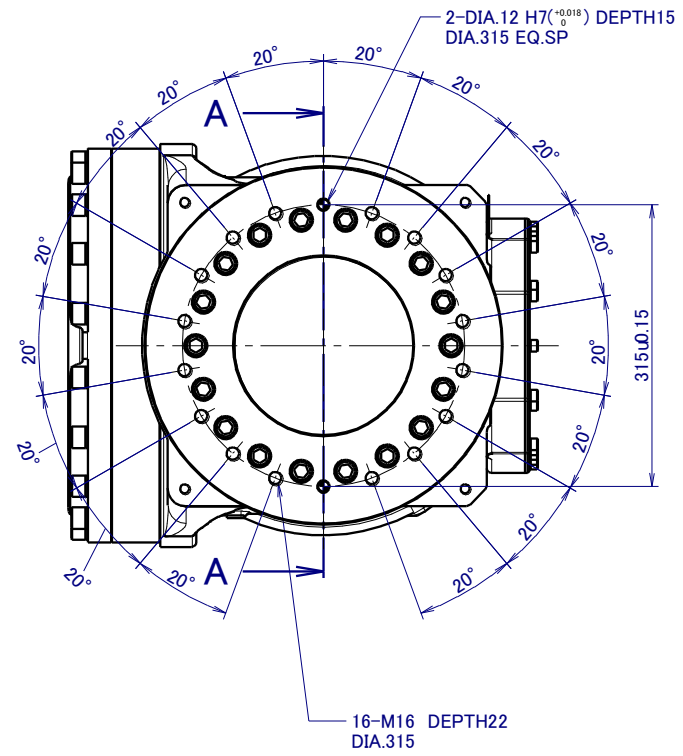

安装尺寸 (底座) (1/2)

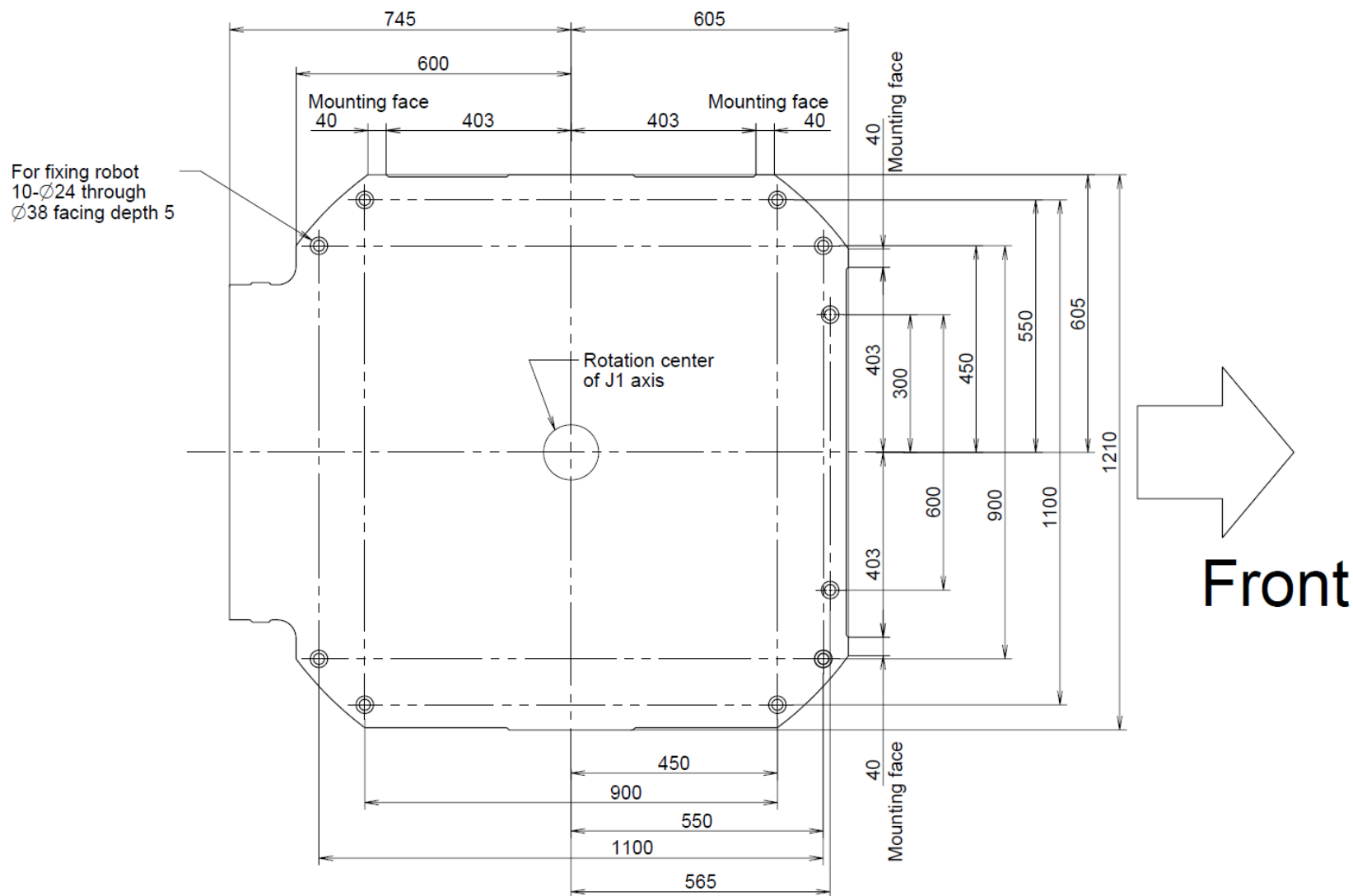

安装尺寸（底座）（2/2）

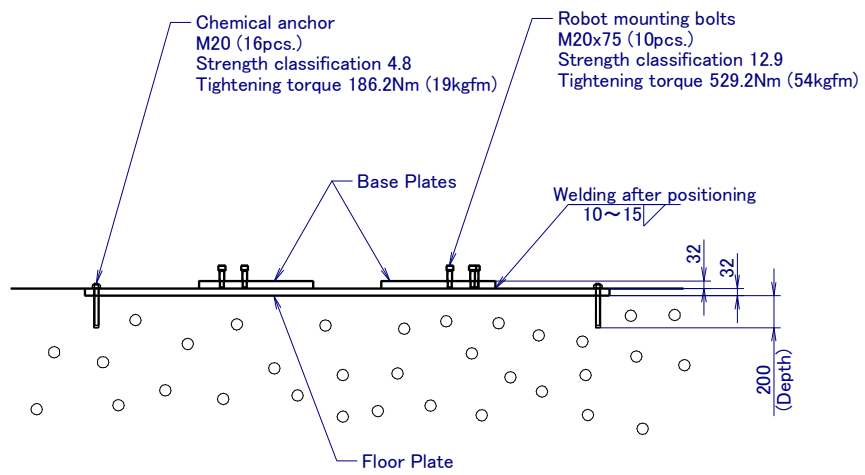
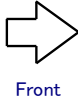
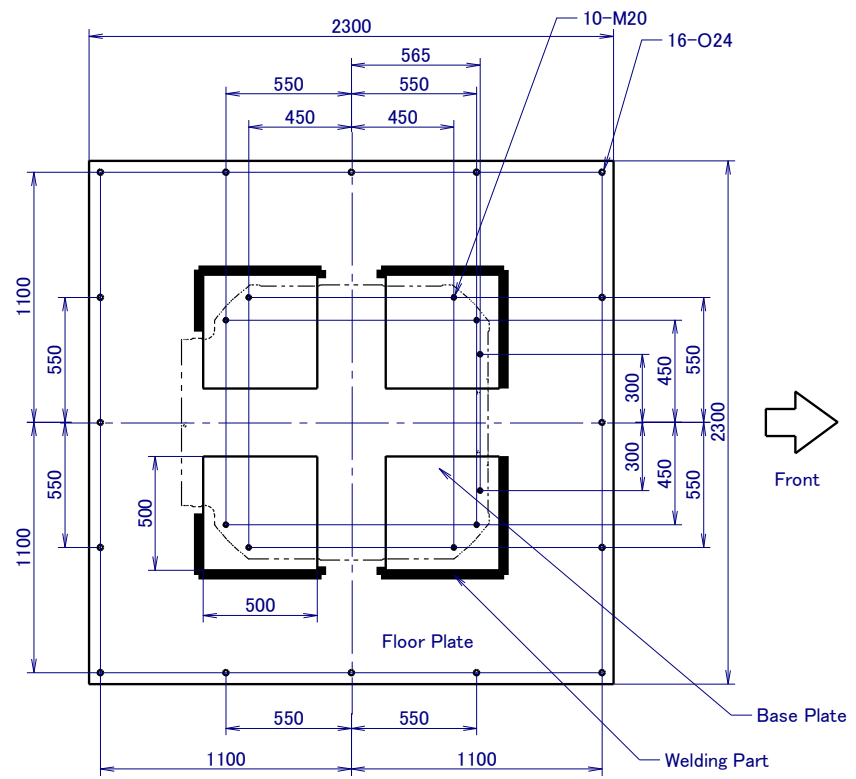

NOTE) Bury the floor plate in concrete.

设备安装面尺寸

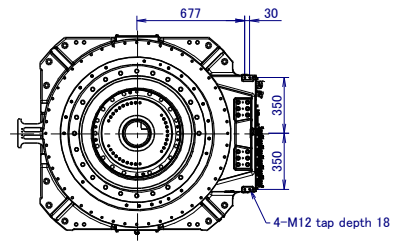
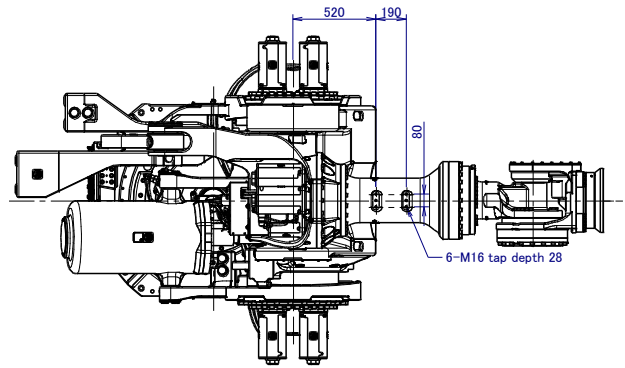

SECTION A-A

