

# FANUC机器人 M-900iB/280

# 手腕允许负载曲线图

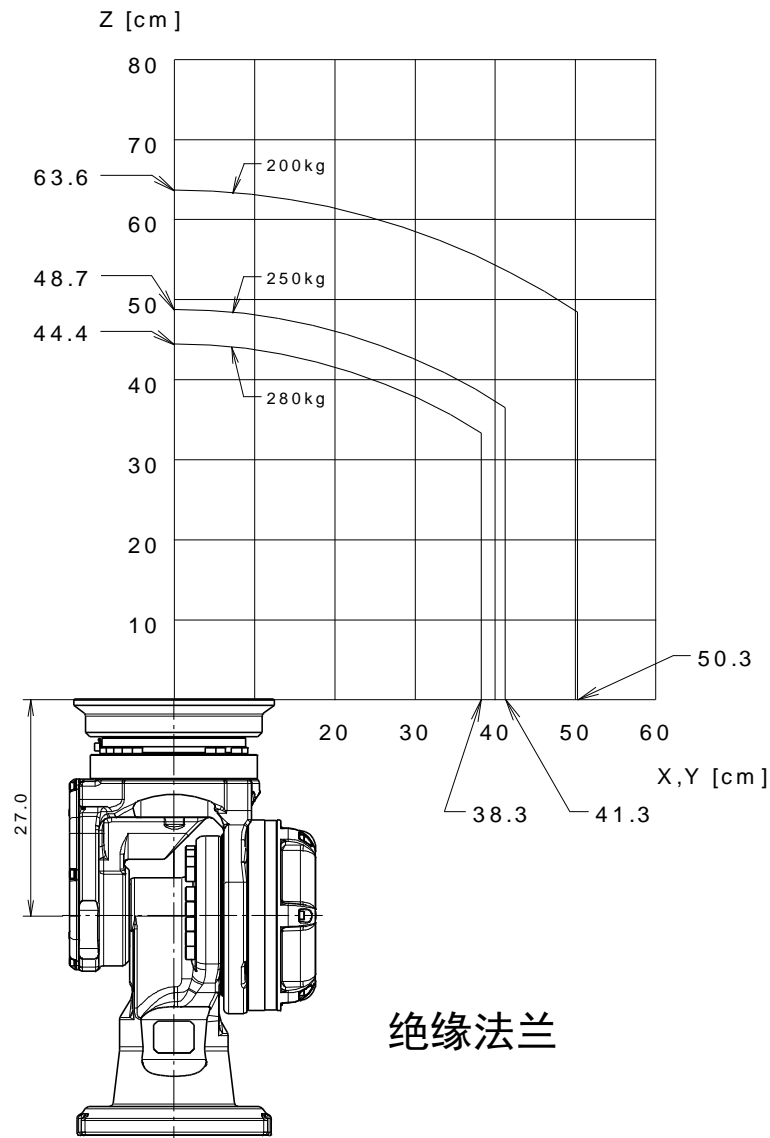

## 复合负载曲线图（标准惯量模式）

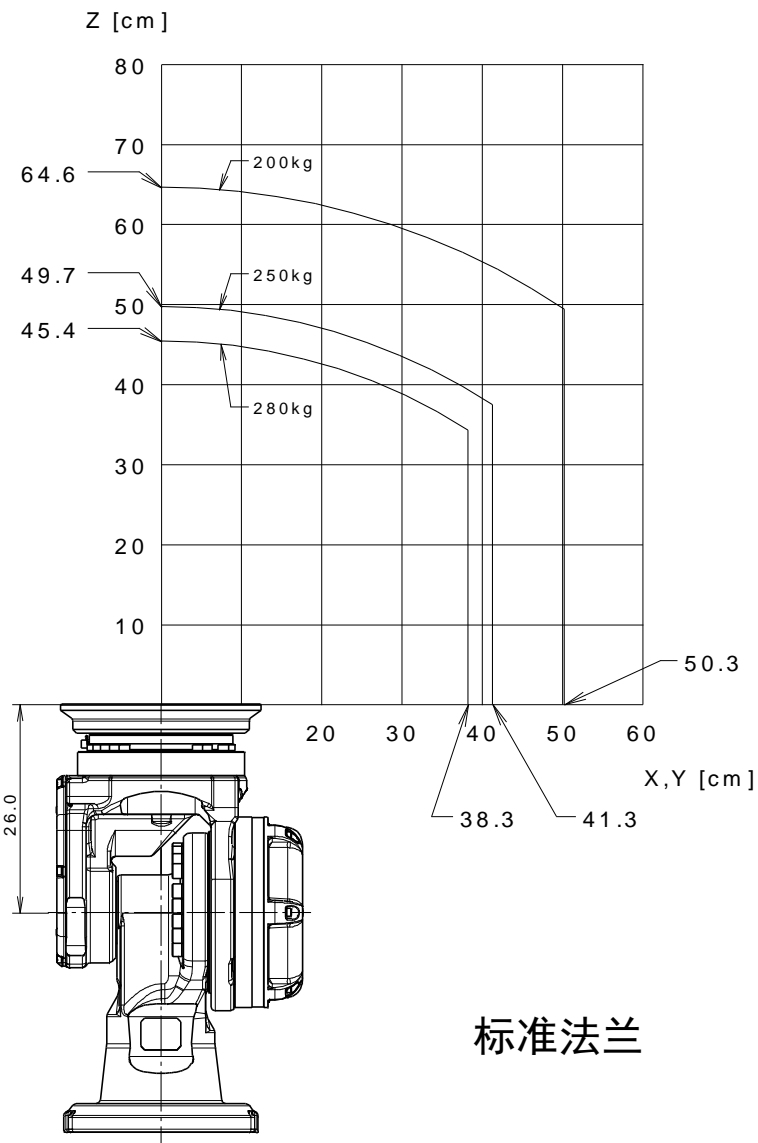
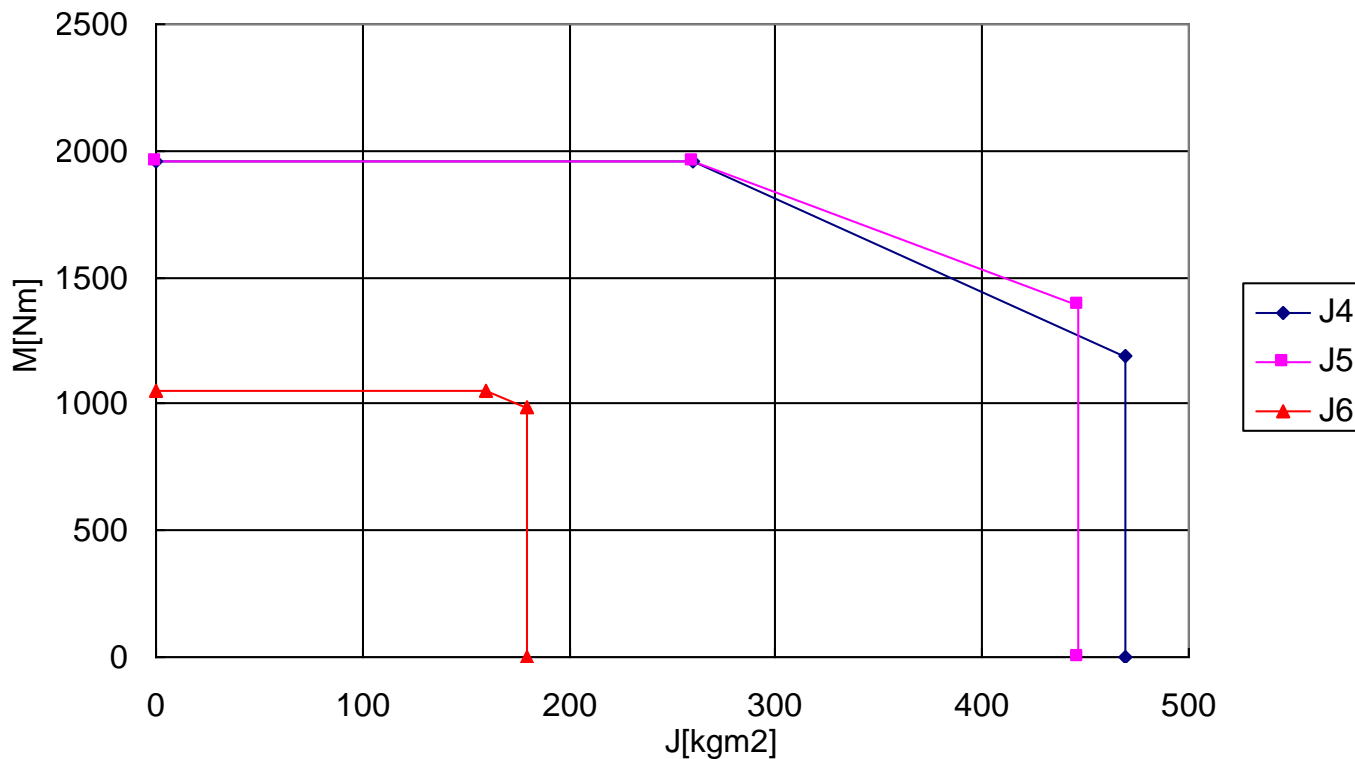

标准规格数据

转矩 (Nm)			惯量 (kgm <sup>2</sup> )			质量 (kg)
J4	J5	J6	J4	J5	J6	
1960	1960	1050	260	260	160	280

## 复合负载曲线图（高惯量模式）

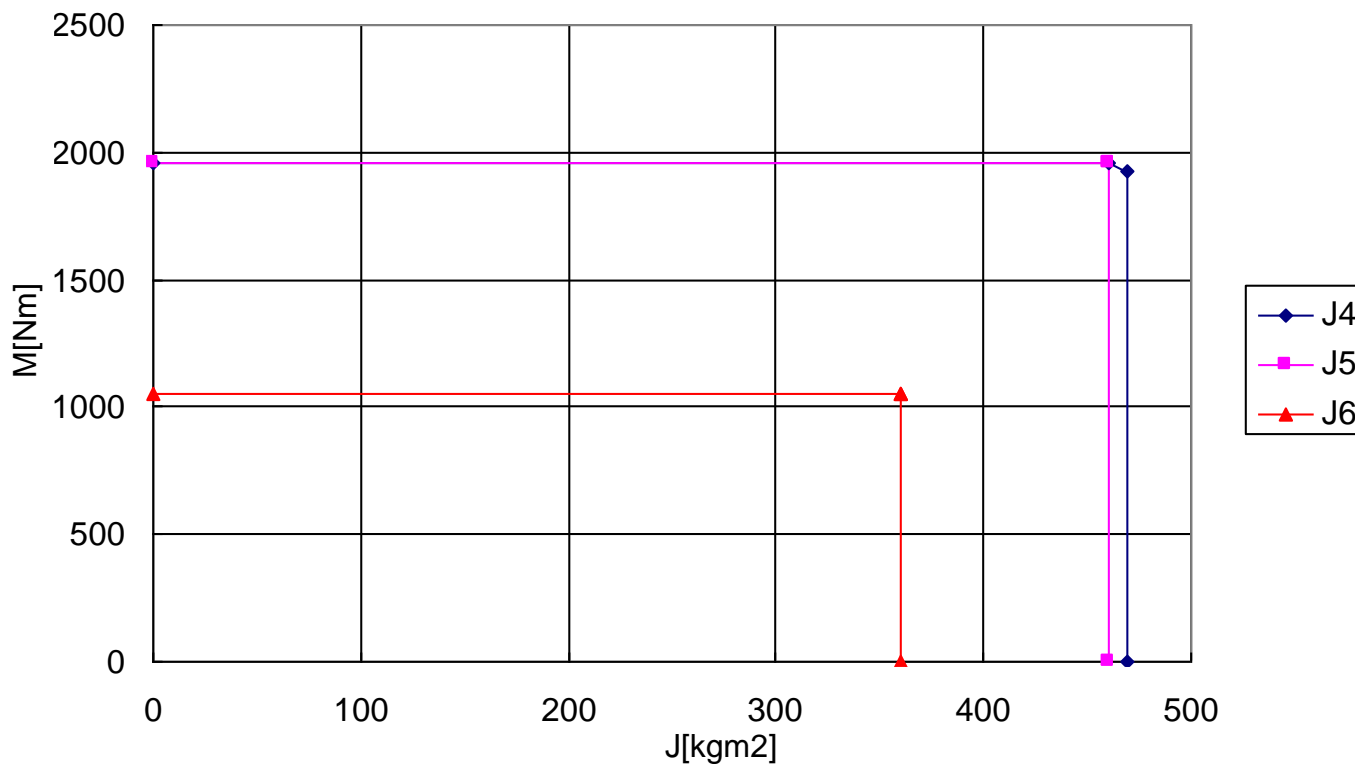

标准规格数据

转矩 (Nm)			惯量 (kgm <sup>2</sup> )			质量 (kg)
J4	J5	J6	J4	J5	J6	
1960	1960	1050	460	460	360	280

## 手腕负载和J3负载曲线图

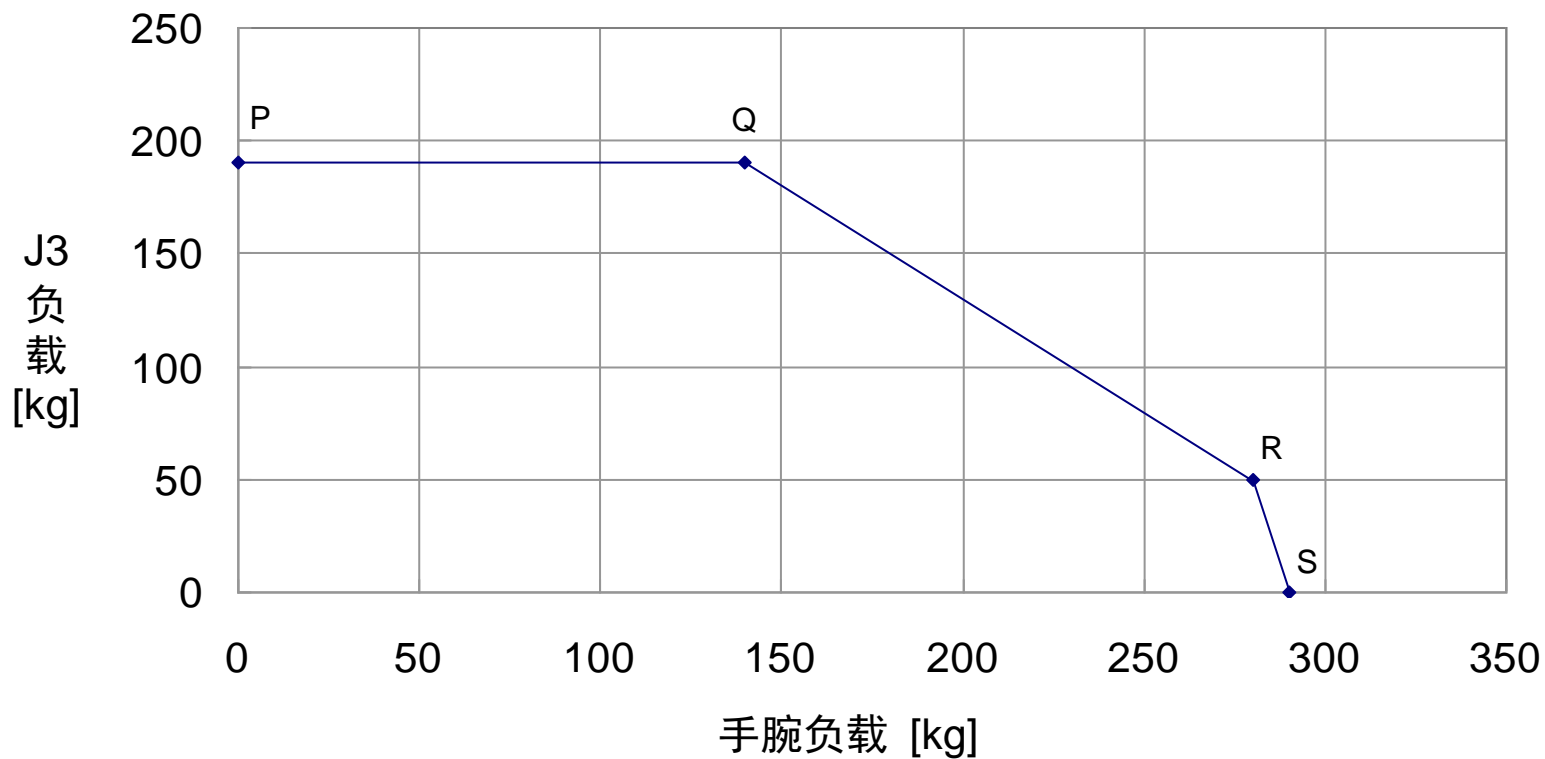

	P	Q	R	S
手腕负载	0	140	280	290
J3 负载	190	190	50	0

# 末端执行器安装面尺寸

标准法兰

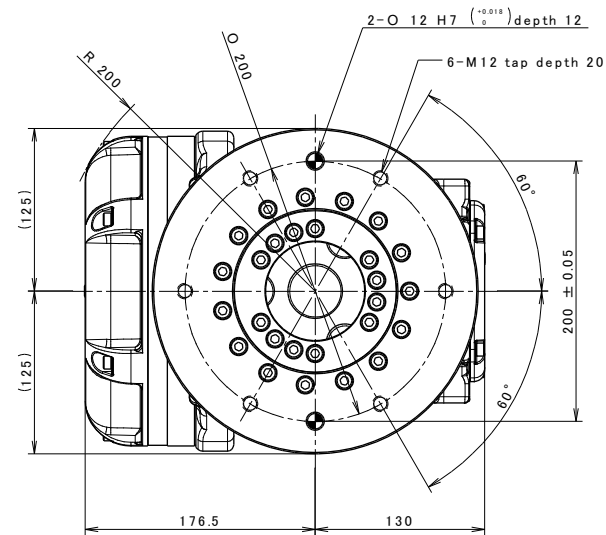
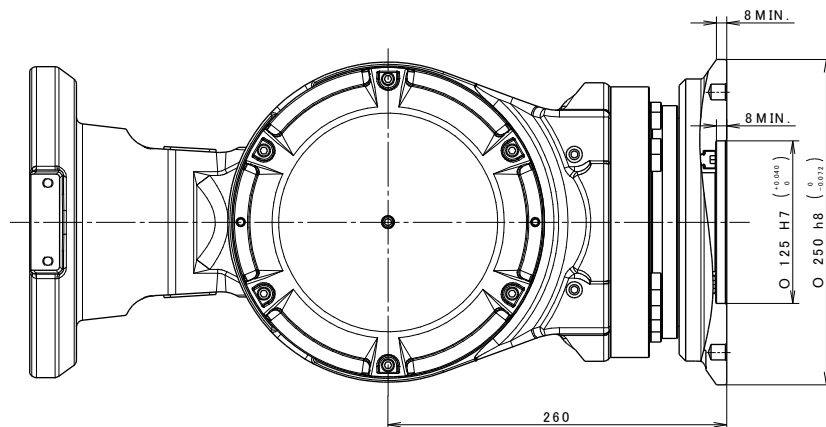

绝缘法兰

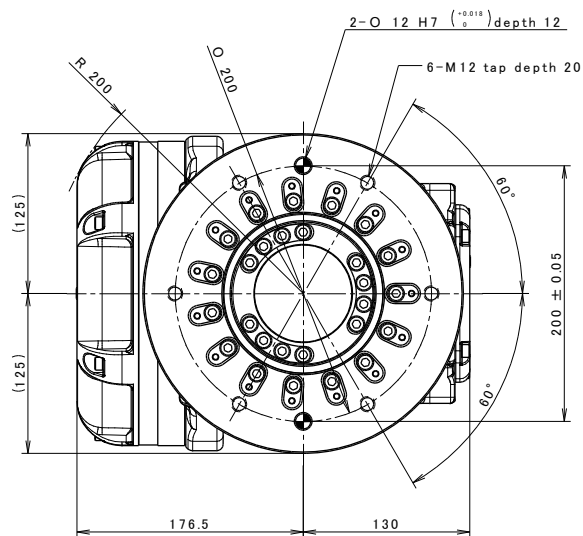
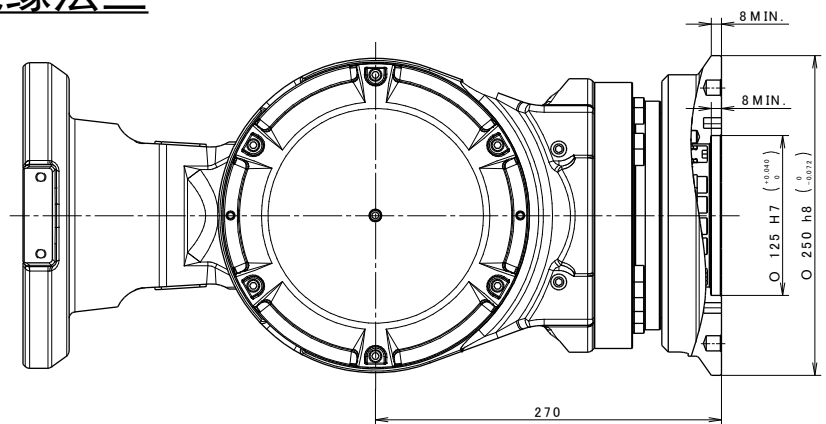



# 标准安装底板尺寸

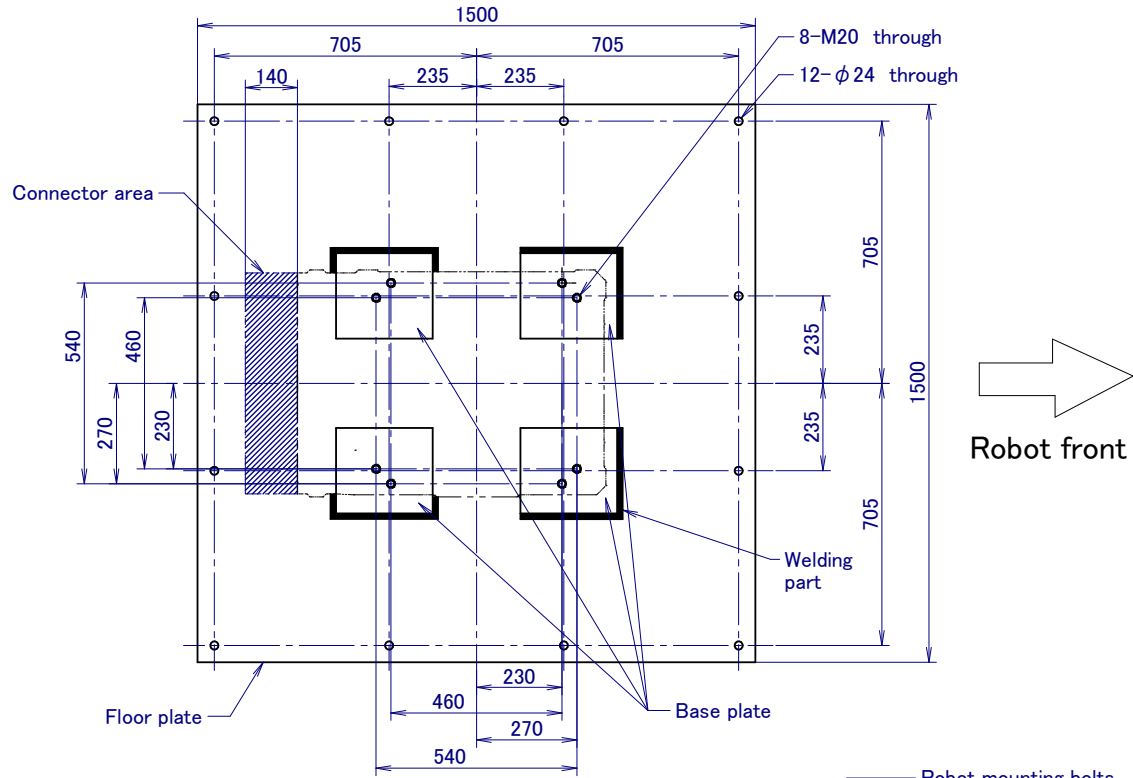

Chemical anchor  
M20 (12 pcs)  
Tensile strength 400N/mm<sup>2</sup> or more  
Tightening torque  
186.2Nm  
(19kgfm)

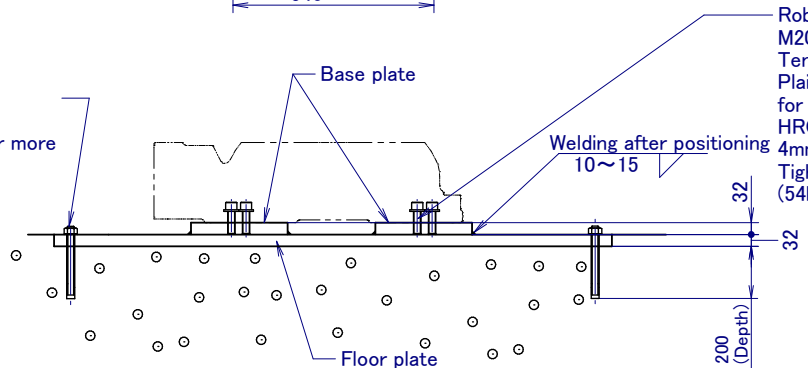

Robot mounting bolts  
M20X65 (8 pcs)  
Tensile strength 1200N/mm<sup>2</sup> or more  
Plain washer  
for M20 (8 pcs)  
HRC35 or more, thickness between  
4mm and 5mm  
Tightening torque 529.2Nm  
(54kgfm)



